

# CABLE CLEATS & ACCESSORIES

SECURING | SUPPORT | FIXING



**PENTA**  
ELECTRICAL SAFETY PRODUCTS

Your life,  
Our work.

[pentaesp.com](http://pentaesp.com)



**At Tuffé, in the heart of the Sarthe region, we have been designing and manufacturing your clamps, OPCs and rollers for over 80 years.**

Since 1940, our industrial site in Tuffé Val de la Chéronne, near Le Mans, has been developing clamps, cable preparation tools and rollers renowned for their robustness and precision. Designed to meet the demands of professionals in the energy, telecommunications, fiber optics, coaxial and specialty cable sectors, our products are built to perform in the most demanding technical environments. From the 1980s onwards, our expertise gained global recognition, driven by strong technical mastery and a constant commitment to innovation.

**Come and see for yourself!**

We invite you to visit our factory in Tuffé: manufacturing processes, quality control, resistance testing... Gain a clear, hands-on understanding of our technical and industrial standards.

**PENTA Electrical Safety Products, your safety partner.**

Our unifying brand, PENTA Electrical Safety Products, embodies our mission: to protect you on every job site, anywhere in the world. We are part of a division dedicated to securing electrical networks.

**PROTECT**

**/ To protect you from the risks associated with work on electrical networks, and to safeguard your working environment.**

We provide personal and collective protective equipment essential to health and safety, fully compliant with current standards and specific requirements.

**SECURE**

**/ To enable you to implement safety measures for de-energized networks, as well as tools for accessing networks and working on live systems.**

We manufacture equipment specifically tailored to your networks, ensuring safe working conditions for all personnel on site.

**WORK**

**/ To enable you to work safely on your job sites.**

We deliver high-performance products that allow you to carry out your installations efficiently.

Our **areas of expertise**

We support you at every stage - production, transport and distribution - with reliable, proven equipment designed to ensure your safety.

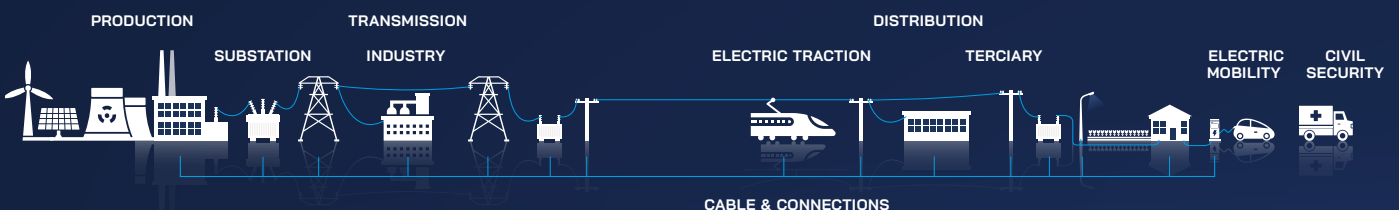

# We are PENTA

A multinational industrial leader, pioneer and expert manufacturer  
in electrical safety solutions, committed to ensuring your safety at every intervention—  
committed to protecting your life!

**We turn your constraints into solutions.**

## / COMMITMENT

Our design office works closely with our customers to develop clamps and tailor-made solutions that are robust, easy to use, and designed for your specific operational environments.

Our approach is built on field insight, technical precision and operational efficiency.

## / PERFORMANCE

Our facility is ISO 9001 certified. Most of our clamps comply with IEC 61914 and undergo rigorous testing: resistance to short circuits, heat and mechanical loads.

You expect reliable, consistent and verifiable performance - **and that is our priority.**

**“Because safety is at the heart of our commitments,  
our mission begins where your life may be at risk.”**

**Your life,  
Our work.**



## Our offering

Our comprehensive range of cable cleats covers a wide variety of configurations and applications: aluminium cable cleats, strap cable cleats, metal supports, as well as all the accessories and fasteners required for a reliable and long-lasting installation.

Strap cable cleats, available in supported, intermediate or suspended versions, provide adjustable and secure fastening for cables, ducts and joints. Their design absorbs both mechanical and electrical stresses, while ensuring quick installation, particularly in suspended or horizontal configurations.

Aluminium cable cleats offer an excellent balance between lightness, strength and long-term durability, even in demanding environments. Modular and robust, our metal supports simplify cable organization, fastening and routing on site.

All our solutions are designed to meet the most stringent standards, including IEC 61914, while also offering cost-effective options that strike the right balance between performance, installation cost and ease of use.

Feel free to contact us for advice or to discover our tailored solutions!

Tél. : (+33) 02 43 71 11 80



# ENGINEERING DEPARTMENT

## EXPERTISE DEDICATED TO YOUR PROJECTS

The Engineering Department at our Tuffé facility supports you in the design and optimization of cable routing and layout, guiding you towards the most suitable supports and accessories to meet your technical and regulatory constraints.

## A TAILORED AND COMPLIANT APPROACH

We carry out customized studies in line with your specifications, ensuring reliable solutions that fully comply with current standards.

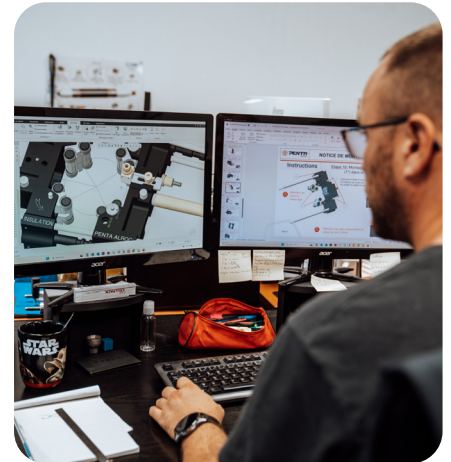

## | Innovation & Reliability



Made  
in France



Global  
presence



Custom product  
design



Product ranges tailored  
to your needs

## | Nos services & prestations



### DESIGN & 3D SIMULATION

- Building or substation basement modeling
- Study of cable routing layouts in PSEM and cable galleries
- Verification of minimum cable bending radius compliance
- Definition of fastening systems based on short-circuit currents (ICC)



### SUPPORT & FIXING SOLUTIONS

- Study and design of cable support structures
- Technical solutions tailored to all cable routing configurations, from the simplest to the most complex
- Installation layout of current transformers according to your constraints and requirements



### TECHNICAL DOCUMENTATION & SUPPORT

- Detailed layout drawings
- Structure assembly instructions
- Documentation and recommendations tailored to project requirements

## Ongoing Support

We work closely with our clients to deliver tailored and sustainable solutions. Each project benefits from in-depth analysis and rigorous follow-up to ensure efficient and safe installation.

For any study request or additional information, our team is at your disposal to address your specific needs and provide optimized technical solutions.

Tél. : (+33) 02 43 71 11 80





Where are ALROC cable cleats mainly used?



1 Underground cable tunnel



2 Industry



3 Hydroelectric power plants



4 Crossing a bridge



5 Power supply for a transformer substation



6 Tunnel



7 Electricity pylon riser



8 Junction chamber



9 Railway network



10 Transformer station gallery



**NAMELY**

These sectors are provided as examples of applications where our cable cleats have already been installed. Each project is unique, and we are able to address a wide range of challenges.

Please contact us for more information.

**CABLE CLEATS  
& ACCESSORIES**

# TABLE OF CONTENTS



# CONTENTS

**ALUMINIUM  
CABLE CLEATS**

**09**

**STRAP  
CABLE CLEATS**

**31**

**METAL  
SUPPORTS**

**43**

**ACCESSORIES &  
SCREWING**

**49**



Scan the QR code above to access our full range  
of cable cleats & accessories on our website  
[www.pentaesp.com](http://www.pentaesp.com) !



4

1

# ALUMINIUM CABLE CLEATS

<b>/ Single cable cleats</b>	<b>10</b>
Single HALF-SHELL Cable cleats	
Hinged single cable cleats	
<b>/ Next-generation cable cleats</b>	<b>14</b>
Single cleat – screw & nut version	
Hinged cable cleats – screw & nut version	
<b>/ Double half-shell cable cleats</b>	<b>16</b>
Double half-shell cable cleats	
Hinged double cable cleats	
<b>/ Triple cable cleats</b>	<b>18</b>
Triple cable cleats	
Hinged triple cable cleats	
<b>/ Special cable cleats</b>	<b>20</b>
Set of insulating connectors	
<b>/ Accessories for aluminium cable cleats</b>	<b>22</b>
Threaded rods	
Articulated rod	
Baseplate and plates	
Cleat supports	
<b>/ Protective liners</b>	<b>26</b>
Standard liners	
Liners for 3 cables	
<b>/ key</b>	<b>28</b>



**CABLE CLEATS & ACCESSORIES**  
**ALUMINIUM CABLE CLEATS**  
**SINGLE CABLE CLEATS**

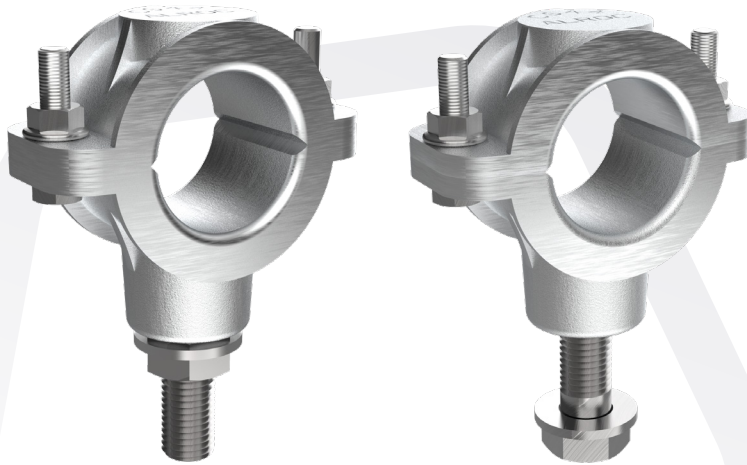

CS\*\*V

CS\*\*E

**/ SINGLE HALF-SHELL CABLE CLEATS**

**/ DESCRIPTION**

- Horizontal or vertical support of a single cable.
- Designed for the fixing of MV cables of diameters from 28 to 39 mm.
- Screw or nut version (M16).

**/ MATERIAL**

- AS13 aluminium alloy + stainless steel

**✓ Supplied with the cable cleat**

- Closing screwing
- Fixing screwing

**+ To be ordered separately**

- Protection for single cable cleat (see page 26)

**/ Option**

- > M12 screwing available on request

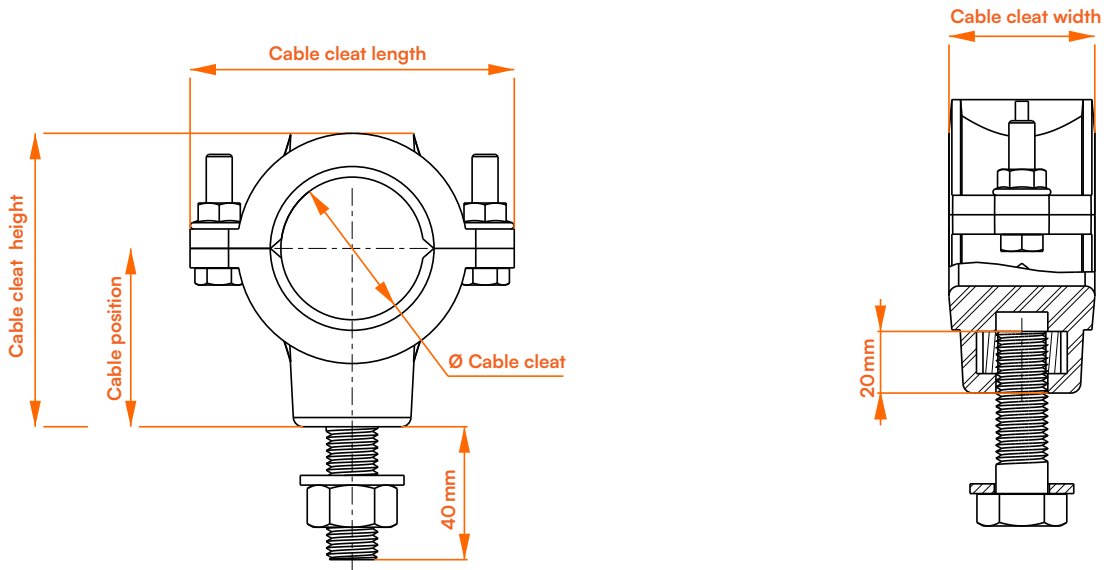

Cable cleat reference		Cable cleat Ø	Length	Width	Height	Cable position	≤ Ø < cable	Protection reference	Protection thickness
M16 screw	M16 nut								
CS 44 V*	CS 44 E*	44 mm	100 mm	45 mm	91 mm	55 mm	28 to 32 mm	PC 10-44	10 mm
							32 to 35 mm	PC 8-44	8 mm
CS 47,5 V	CS 47,5 E	47,5 mm					35 to 37 mm	PC 10-47,5	10 mm
							37 to 39 mm	PC 8-47,5	8 mm

\* Longer lead times apply to these references: see Next-generation cable cleats (pages 14–15) for shorter lead times.





## CABLE CLEATS & ACCESSORIES

### ALUMINIUM CABLE CLEATS

#### HINGED SINGLE CABLE CLEATS



CSC\*\*V

CSC\*\*E

## / HINGED SINGLE CABLE CLEATS

### / DESCRIPTION

- Horizontal or vertical support of a single cable.
- Cable diameter from 42 to 142 mm.
- Screw or nut version (M16).

### / MATERIAL

- AS13 aluminium alloy + stainless steel

### ✓ Supplied with the cable cleat

- Closing screwing

### + To be ordered separately

- Tools: facilitate closing (see page 28).
- Protection for single cable cleat (see page 27).
- Fixing screwing for M16 hinged single cable cleat (see page 51).

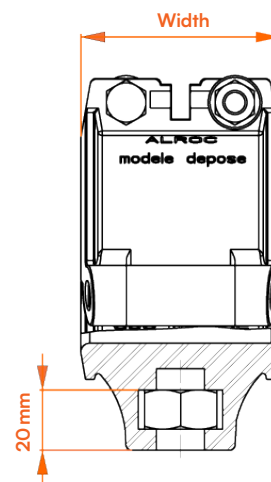
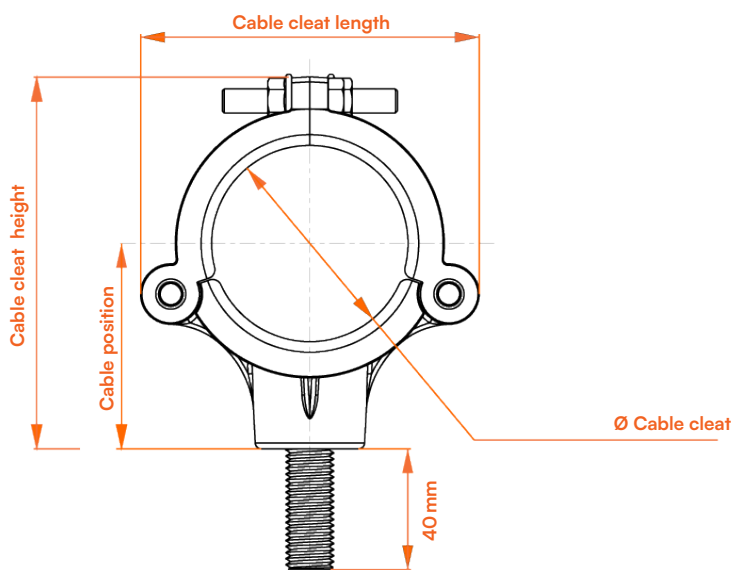



Cable cleat reference		Cable cleat Ø	Length	Width	Height	Cable position	≤ Ø < cable	Protection reference	Protection thickness
M16 screw	M16 nut								
CSC 60 V	CSC 60 E	60 mm	112 mm	66 mm	121 mm	68 mm	42 to 44 mm	PCA 10-60	10 mm
							44 to 47 mm	PCA 8-60	8 mm
CSC 65 V	CSC 65 E	65 mm	121 mm		125 mm	70 mm	47 to 49 mm	PCA 10-65	10 mm
							49 to 52 mm	PCA 8-65	8 mm
CSC 70 V*	CSC 70 E*	70 mm	121 mm		131 mm	71 mm	52 to 54 mm	PCA 10-70	10 mm
							54 to 57 mm	PCA 8-70	8 mm
CSC 75 V	CSC 75 E	75 mm	126 mm	138 mm	74 mm	57 to 59 mm	PCA 10-75	10 mm	
						59 to 62 mm	PCA 8-75	8 mm	
CSC 80 V	CSC 80 E	80 mm	134 mm	80 mm	144 mm	77 mm	62 to 64 mm	PCA 10-80	10 mm
							64 to 67 mm	PCA 8-80	8 mm
CSC 85 V	CSC 85 E	85 mm	140 mm		150 mm	80 mm	67 to 69 mm	PCA 10-85	10 mm
							69 to 72 mm	PCA 8-85	8 mm
CSC 90 V	CSC 90 E	90 mm	145 mm		158 mm	82 mm	72 to 74 mm	PCA 10-90	10 mm
							74 to 77 mm	PCA 8-90	8 mm
CSC 95 V	CSC 95 E	95 mm	151 mm	163 mm	86 mm	77 to 79 mm	PCA 10-95	10 mm	
						79 to 82 mm	PCA 8-95	8 mm	
CSC 100 V	CSC 100 E	100 mm	157 mm	100 mm	168 mm	88 mm	82 to 84 mm	PCA 10-100	10 mm
							84 to 87 mm	PCA 8-100	8 mm
CSC 105 V	CSC 105 E	105 mm	163 mm		175 mm	92 mm	87 to 89 mm	PCA 10-105	10 mm
							89 to 92 mm	PCA 8-105	8 mm
CSC 110 V	CSC 110 E	110 mm	169 mm		180 mm	94,50 mm	92 to 94 mm	PCA 10-110	10 mm
							94 to 97 mm	PCA 8-110	8 mm
CSC 115 V	CSC 115 E	115 mm	174 mm	186 mm	96 mm	97 to 99 mm	PCA 10-115	10 mm	
						99 to 102 mm	PCA 8-115	8 mm	
CSC 120 V	CSC 120 E	120 mm	180 mm	191 mm	99 mm	102 to 104 mm	PCA 10-120	10 mm	
						104 to 107 mm	PCA 8-120	8 mm	
CSC 125 V	CSC 125 E	125 mm	186 mm	194 mm	101,50 mm	107 to 109 mm	PCA 10-125	10 mm	
						109 to 112 mm	PCA 8-125	8 mm	
CSC 130 V	CSC 130 E	130 mm	192 mm	205 mm	108 mm	112 to 114 mm	PCA 10-130	10 mm	
						114 to 117 mm	PCA 8-130	8 mm	
CSC 135 V	CSC 135 E	135 mm	198 mm	210 mm	109 mm	117 to 119 mm	PCA 10-135	10 mm	
						119 to 122 mm	PCA 8-135	8 mm	
CSC 140 V	CSC 140 E	140 mm	201 mm	214 mm	111,50 mm	122 to 124 mm	PCA 10-140	10 mm	
						124 to 127 mm	PCA 8-140	8 mm	
CSC 145 V	CSC 145 E	145 mm	206 mm	220 mm	114 mm	127 to 129 mm	PCA 10-145	10 mm	
						129 to 132 mm	PCA 8-145	8 mm	
CSC 150 V	CSC 150 E	150 mm	210,30 mm			132 to 134 mm	PCA10-150	10 mm	
						134 to 137 mm	PCA8-150	8 mm	
CSC 155 V	CSC 155 E	155 mm	215 mm			137 to 139 mm	PCA 10-155	10 mm	
						139 to 142 mm	PCA 8-155	8 mm	

\* Longer lead times apply to these references: see Next-generation cable cleats (pages 14–15) for shorter lead times.



# NEXT-GENERATION CABLE CLEATS



## / SINGLE CABLE CLEAT SCREW & NUT VERSION

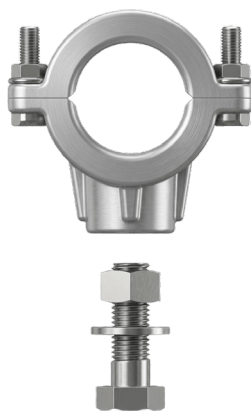
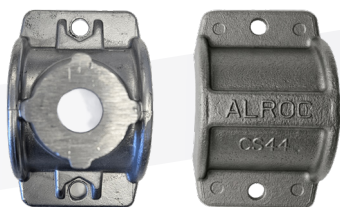
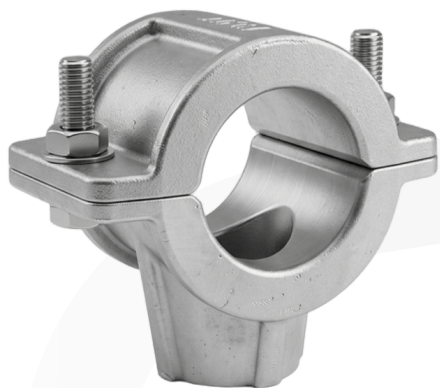

M16 drive

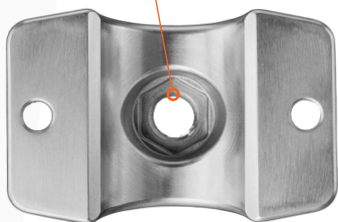

CS\*\*VE

### / DESCRIPTION

The simplified hinged cable cleat CS\*\*VE is designed to provide secure support for a cable, whether in horizontal or vertical position, while ensuring easy handling, quick installation and optimal strength.

Its interchangeable M16 screwing makes this cable cleat a hybrid (male—female), allowing you to adapt the fixing system to all types of supports.

It is compatible with cables ranging from 28 mm to 35 mm in diameter, depending on the selected liner.

### / MATERIAL

- AS13 aluminium alloy

### ✓ Supplied with the cable cleat

- Closing screwing
- M16 fixing screwing

### ⊕ To be ordered separately

- EPDM protection for single cable cleat

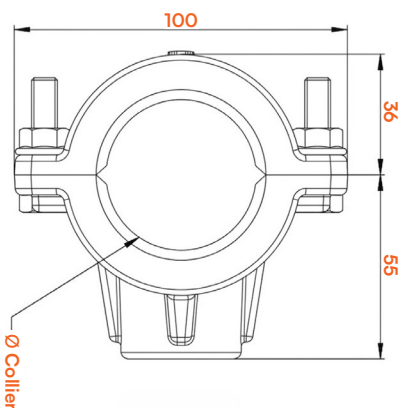
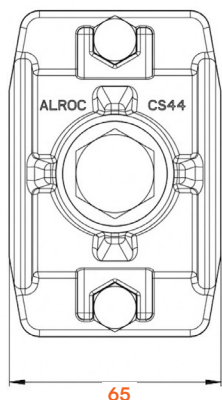

Crédit Photo : Haute Tension Service Occitanie

Cable cleat reference	Cable cleat $\varnothing$	Length	Width	Height	Protection thickness	Hybrid screw/nut	$\leq \varnothing <$ cable	Protection reference
CS44VE	44 mm	100 mm	65 mm	91 mm	10 mm	M16	28 to 32 mm	PC10-44VE
					8 mm		32 to 35 mm	PC8-44VE



## / HINGED SINGLE CABLE CLEATS SCREW & NUT VERSION

### / DESCRIPTION

The simplified hinged cable cleat CNG70 is designed to provide secure support for a cable, whether in a horizontal or vertical position. Its optimized design is based on a three-part assembly connected by a removable hinge system, ensuring easy handling, quick installation and optimal strength.

Thanks to its simplified closing system using two screws, this cable cleat ensures excellent cable retention while facilitating assembly and disassembly operations.

Its interchangeable M16 screwing makes this cable cleat a hybrid (male—female), allowing you to adapt the fixing system to all types of supports.

It is compatible with cables ranging from 52 mm to 57 mm in diameter, depending on the selected liner.

### / MATERIAL

- AS7G06 aluminium alloy

### ✓ Supplied with the cable cleat

- Closing screwing
- Fixing screwing

### + To be ordered separately

- Tool for easier cable cleat closing and nut tightening
- Protection for single cable cleat (use the same protection as for Ø70 mm hinged single cable cleats)

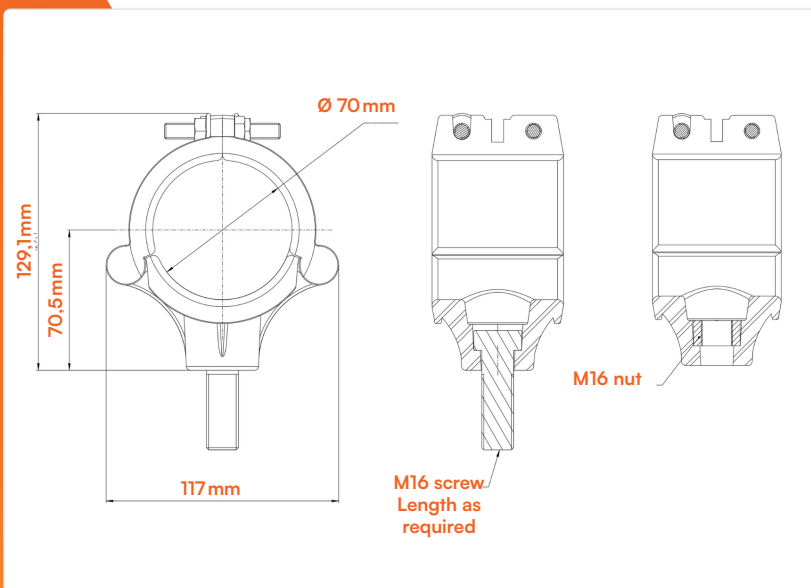

Cable cleat reference	Cable cleat Ø	Length	Width	Height	Cable position	Protection thickness	Hybrid screw/nut	≤ Ø < cable	Protection reference
CNG70	70 mm	117 mm	66 mm	129 mm	71 mm	10 mm	M16	52 to 54 mm	PCA10-70
						8 mm		54 to 57 mm	PCA8-70



CABLE CLEATS & ACCESSORIES

ALUMINIUM CABLE CLEATS  
DOUBLE HALF-SHELL CABLE CLEATS



CDS\*\*V

CDS\*\*E



/ DOUBLE HALF-SHELL  
CABLE CLEATS

/ DESCRIPTION

- Horizontal or vertical fixing of two cables
- Designed for the fixing of MV cables of diameter 28 to 39 mm..
- Screw or nut version (M16)

/ MATERIAL

- AS13 aluminium alloy + stainless steel

✓ Supplied with the cable cleat

- Protective liners
- M8 closing screwing
- Fixing screwing

/ Option

- > M12 screwing available on request
- > Configuration possible with two different cable cleats (e.g. CS44 and CS47.5)
- > Simplified 3D files available on request

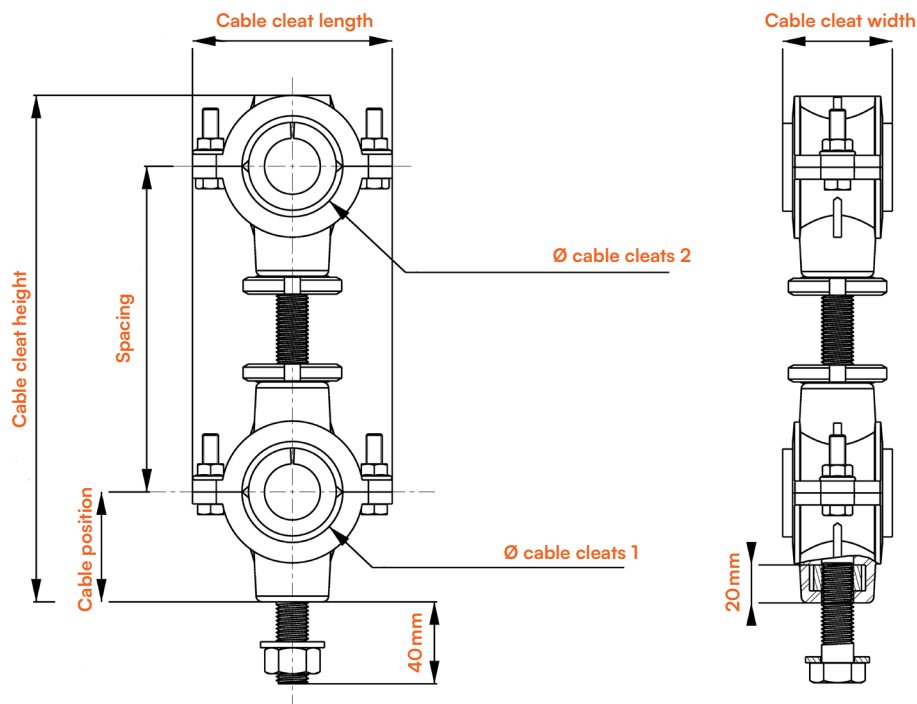

Cable cleat reference		Cable cleat Ø	Length	Width	Height	Cable position	Spacing	Protection thickness	≤ Ø < cable	Protection reference
M16 screw	M16 nut									
CDS 44 V-F10	CDS 44 E-F10	44 mm	100 mm	55 mm	255 mm	55 mm	165 mm (Spacing can be adjusted)	10 mm	28 to 32 mm	PC 10-44 (included)
CDS 44 V-F8	CDS 44 E-F8							8 mm	32 to 35 mm	PC 8-44 (included)
CDS 47.5 V-F10	CDS 47.5 E-F10	47.5 mm	100 mm	55 mm	255 mm	55 mm	165 mm (Spacing can be adjusted)	10 mm	35 to 37 mm	PC 10-47.5 (included)
CDS 47.5 V-F8	CDS 47.5 E-F8							8 mm	37 to 39 mm	PC 8-47.5 (included)



## / HINGED DOUBLE CABLE CLEATS

### / DESCRIPTION

- Horizontal or vertical fixing of two cables
- Designed for the fixing of 630 mm<sup>2</sup> cables of diameter 46 to 57 mm
- Screw or nut version (M16)
- Reinforced with external and central ribs on all three parts of the cable cleat

### / MATERIAL

- AlSi3 aluminium alloy + stainless steel

### ✓ Supplied with the cable cleat

- M8 closing screwing

### / Option

- > Liners
- > Fixing screwing
- > Closing tool
- > M12 screwing available on request
- > Simplified 3D files available on request

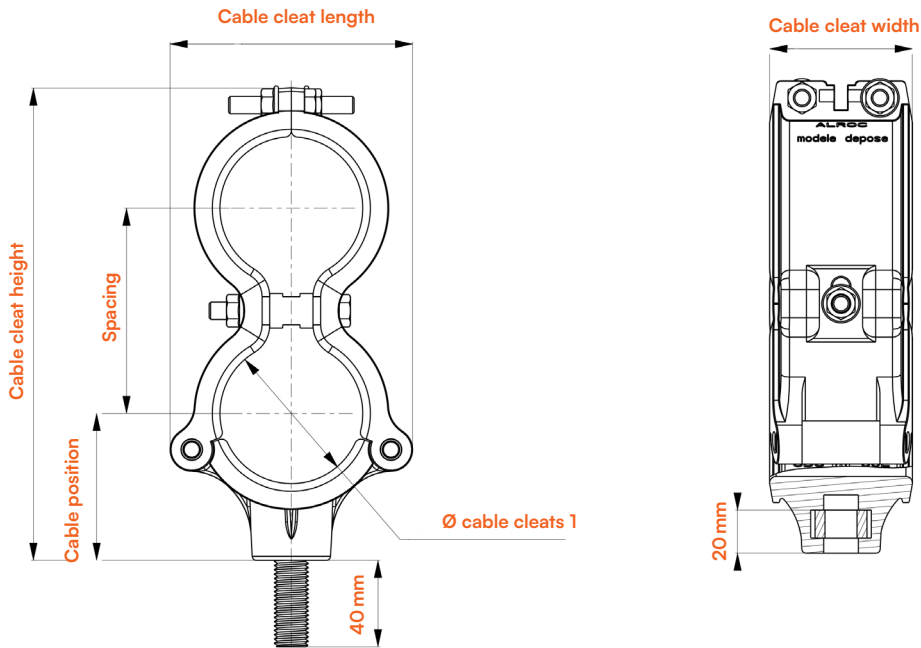

Cable cleat reference		Cable cleat Ø	Length	Width	Height	Cable position	Spacing	Protection thickness	≤ Ø < cable	Protection reference
M16 screw	M16 nut									
CDC 60 V	CDC 60 E	60 mm	112 mm	66 mm	217 mm	68 mm	95 mm	10 mm	46 to 49 mm	PCD 10-60
								8 mm	49 to 52 mm	PCD 8-60
CDC 66 V	CDC 66 E	66 mm	112 mm	66 mm	217 mm	68 mm	95 mm	10 mm	52 to 55 mm	PCD 10-66
								8 mm	55 to 57 mm	PCD 8-66



ALUMINIUM CABLE CLEATS  
TRIPLE CABLE CLEATS



TRIPLE CABLE CLEATS

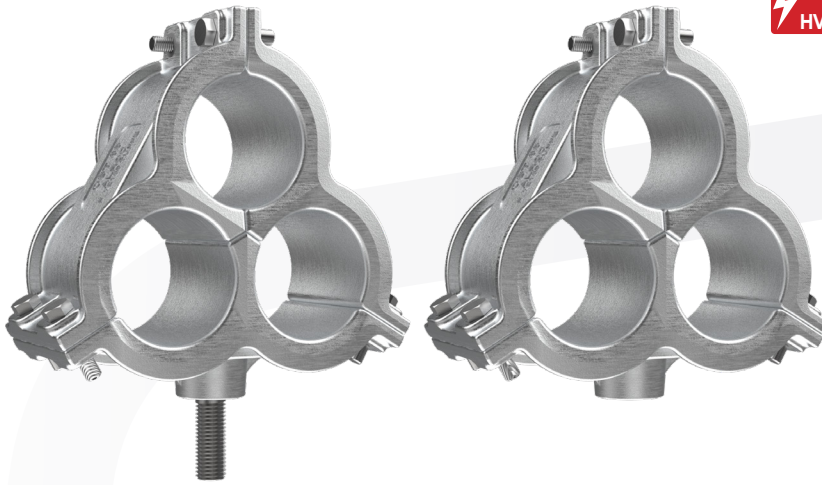

CST\*\*V

CST\*\*E

DESCRIPTION

- Horizontal or vertical fixing of three cables
- Trefoil arrangement with each phase independent
- Installation of all three cables simultaneously
- Screw or nut version (M16)

MATERIAL

- ASI3 aluminium alloy + stainless steel

Supplied with the cable cleat

- Protective liner
- M16 closing screwing
- Fastening screws

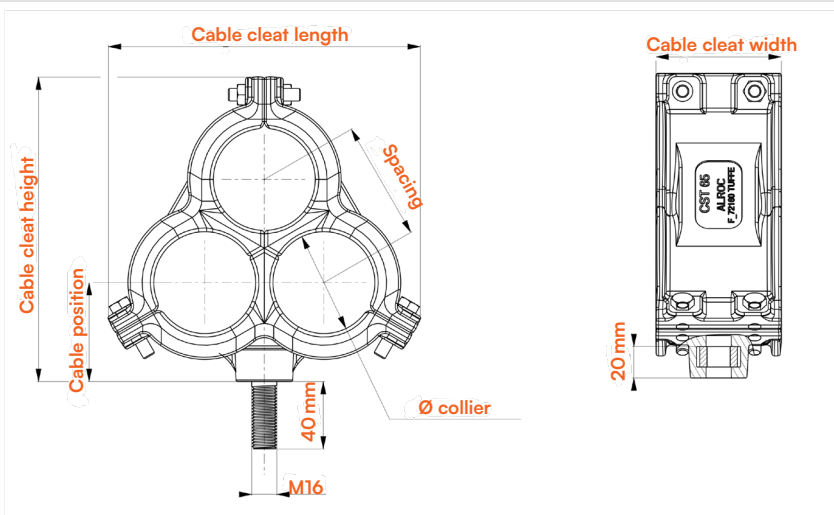

Cable cleat reference		Cable cleat Ø	Length	Width	Height	Cable position	Spacing	Protection thickness	≤ Ø < cable	Protection reference
M16 screw	M16 nut									
CST 60 V	CST 60 E	60 mm	198 mm	80 mm	194,50 mm	63 mm	76 mm	10 mm	42 to 44 mm	PCT 10-60
								8 mm	44 to 47 mm	PCT 8-60
CST 65 V	CST 65 E	65 mm	198 mm	80 mm	194,50 mm	63 mm	76 mm	10 mm	47 to 49 mm	PCT 10-65
								8 mm	49 to 52 mm	PCT 8-65
CST 70 V	CST 70 E	70 mm	198 mm	80 mm	194,50 mm	63 mm	76 mm	10 mm	52 to 54 mm	PCT 10-70
								8 mm	54 to 57 mm	PCT 8-70
CST 75 V	CST 75 E	75 mm	198 mm	80 mm	194,50 mm	63 mm	76 mm	10 mm	57 to 59 mm	PCT 10-75
								8 mm	59 to 62 mm	PCT 8-75
CST 80 V	CST 80 E	80 mm	235 mm	80 mm	231 mm	72 mm	96 mm	10 mm	62 to 64 mm	PCT 10-80
								8 mm	64 to 67 mm	PCT 8-80
CST 85 V	CST 85 E	85 mm	235 mm	80 mm	231 mm	72 mm	96 mm	10 mm	67 to 69 mm	PCT 10-85
								8 mm	69 to 72 mm	PCT 8-85



CTSI\*\*



## / HINGED TRIPLE CABLE CLEATS

### / DESCRIPTION

- Horizontal or vertical fixing of three cables. • Trefoil arrangement with each phase independent.
- Cable tightening phase by phase, enabling easier installation without temporary cable positioning.

### / MATERIAL

- AS13 and AS7G06 aluminium alloys + stainless steel.

### ✓ Supplied with the cable cleat

- Closing screwing.

### ⊕ To be ordered separately

- Tools: facilitate closing (see page 28)
- Protection for corresponding cable cleat (x3) (see page 27).
- Fixing screwing for triple cable cleat (see page 51).

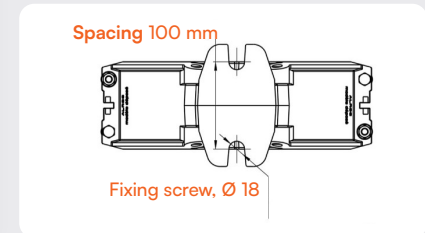
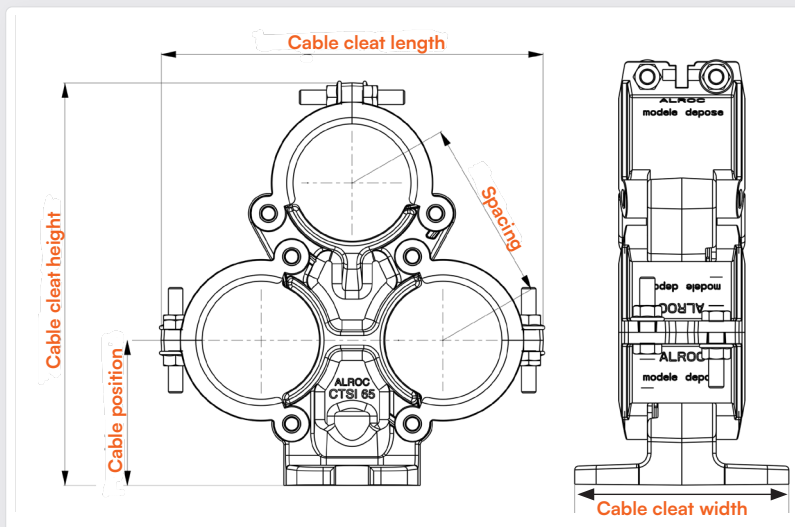

Cable cleat reference	Cable cleat Ø	Length	Width	Height	Cable position	Spacing	Fixing	Protection thickness	≤ Ø < cable	Protection reference
CTSI 65	65 mm	212 mm	112 mm	223 mm	80 mm	100 mm	74 mm	10 mm	47 to 49 mm	PCA 10-65
								8 mm	49 to 52 mm	PCA 8-65
CTSI 85	85 mm	258 mm	128 mm	275 mm	100 mm	125 mm	88 mm	10 mm	67 to 69 mm	PCA 10-85
								8 mm	69 to 72 mm	PCA 8-85
CTSI 90	90 mm	270 mm	128 mm	283 mm	100 mm	132 mm	88 mm	10 mm	72 to 74 mm	PCA 10-90
								8 mm	74 to 77 mm	PCA 8-90
CTSI 100	100 mm	302 mm	140 mm	309 mm	105 mm	145 mm	100 mm	10 mm	82 to 84 mm	PCA 10-100
								8 mm	84 to 87 mm	PCA 8-100
CTSI 110	110 mm	310 mm	140 mm	336 mm	110 mm	160 mm	100 mm	10 mm	92 to 94 mm	PCA 10-110
								8 mm	94 to 97 mm	PCA 8-110
CTSI 115	115 mm	330 mm	140 mm	339 mm	115 mm	160 mm	100 mm	10 mm	97 to 99 mm	PCA 10-115
								8 mm	99 to 102 mm	PCA 8-115



## CABLE CLEATS & ACCESSORIES

### ALUMINIUM CABLE CLEATS SPECIAL CABLE CLEATS



## / SET OF INSULATING CONNECTORS

### / DESCRIPTION

- Designed for fastening cables beneath substations.
- Insulating link assemblies (GTC-PCA) are complete systems including cable cleats, liners, screwing and the insulating link (ELI).
- Each cable run is independent to facilitate installation and maintenance. Spacing between two cables: 230 mm.

### / MATERIAL

- Insulating plastic

### ✓ Supplied with the cable cleat

- Closing screwing
- Cable cleat liners
- Fixing screwing

### ⊕ To be ordered separately

- Tool for easier cable cleat closing and nut tightening

### / Option

- > Special assemblies available on request
- > Mounting plate



Photo credit : RTE

Reference	Visual	Cable cross-section 12/20 kV	Cable diameter 630 mm <sup>2</sup>	Cable diameter 50 mm <sup>2</sup> or 95 mm <sup>2</sup>	Fixing
ELI			N/A		N/A
GTC1-NEX-PCA GTC1-SPE-PCA GTC 1-PCA		1 cable of 630 mm <sup>2</sup>	47 to 49 mm 49 to 52 mm 52 to 54 mm	N/A N/A N/A	M16 screw
GTC1-95-NEX-PCA GTC1-95-SPE-PCA GTC 1-95-PCA		1 cable of 630 mm <sup>2</sup> 1 cable of 95 mm <sup>2</sup>	47 to 49 mm 49 to 52 mm 52 to 54 mm	32 to 35 mm 32 to 35 mm 32 to 35 mm	M16 screw
GTC1-50-NEX-PCA GTC1-50-SPE-PCA GTC 1-50-PCA		1 cable of 630 mm <sup>2</sup> 1 cable of 50 mm <sup>2</sup>	47 to 49 mm 49 to 52 mm 52 to 54 mm	28 to 32 mm 28 to 32 mm 28 to 32 mm	M16 screw
GTC2-NEX-PCA GTC2-SPE-PCA GTC 2-PCA		2 cable of 630 mm <sup>2</sup>	47 to 49 mm 49 to 52 mm 52 to 54 mm	N/A N/A N/A	M16 screw
GTC2E-NEX-PCA GTC2E-SPE-PCA GTC 2E-PCA		2 cable of 630 mm <sup>2</sup>	47 to 49 mm 49 to 52 mm 52 to 54 mm	N/A N/A N/A	M16 nut
GTC2-95-NEX-PCA GTC2-95-SPE-PCA GTC 2-95-PCA		2 cable of 630 mm <sup>2</sup> 1 cable of 95 mm <sup>2</sup>	47 to 49 mm 49 to 52 mm 52 to 54 mm	32 to 35 mm 32 to 35 mm 32 to 35 mm	M16 screw
GTC2-50-NEX-PCA GTC2-50-SPE-PCA GTC 2-50-PCA		2 cable of 630 mm <sup>2</sup> 1 cable of 50 mm <sup>2</sup>	47 to 49 mm 49 to 52 mm 52 to 54 mm	28 to 32 mm 28 to 32 mm 28 to 32 mm	M16 screw





**CABLE CLEATS & ACCESSORIES**

**ALUMINIUM CABLE CLEATS  
ACCESSORIES FOR ALUMINIUM CABLE CLEATS**

Links allow cable cleats to be fixed to supports or surfaces (metal profiles, walls using chemical anchors, etc.).

**/ THREADED ROD CONNECTOR**

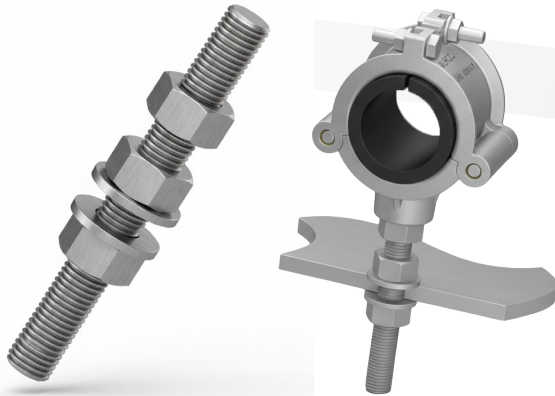

LTF\*\*

**/ DESCRIPTION**

The threaded rod connector is used to fasten a single cable cleat on a surface. They allow straight mounting of single cable cleats, with or without hinges, in M16 or M12 nut versions, and are commonly used by railway companies.

**/ MATERIAL**

Threaded rod link: stainless steel

**✓ Supplied with the cable cleat**

- Fixing screwing

Reference	Length	Thread
LTF16-100	100mm	M16
LTF16-140	140mm	
LTF12-140	140mm	M12
LTF16-170	170mm	M16
LTF16-220	220mm	

**/ ARTICULATED ROD CONNECTOR**



LCA\*\*\*

**/ DESCRIPTION**

M16 articulated rod links are designed for fixing cables in an inclined position. They are compatible with M16 hinged single cable cleats with a diameter of 90 mm or less.

**/ MATERIAL**

Articulated link: stainless steel

**✓ Supplied with the cable cleat**

- Fixing screwing

Reference	Components	Connector's dimensions
LCA-MMI	2 male threads	60 mm 60 mm
LCA-MFI	1 male thread and 1 female thread	60 mm 60 mm
LCA-FFI	2 female threads	60 mm 60 mm





## / THREADED END CABLE CLEATS



### / DESCRIPTION

The M36 threaded end cable cleat allows screw version cable cleats to be connected to a baseplate or to an articulated end cable cleat when the cable is a long way from the support.

### / MATERIAL

- AU4G aluminium alloy

### + To be ordered separately

- Cable cleat, baseplate, nuts, articulated cable cleat extension, etc.

Reference	Length	Threaded length
QCF 70	70 mm	55 mm
QCF 100	100 mm	85 mm
QCF 120	120 mm	105 mm
QCF 130	130 mm	115 mm
QCF 150	150 mm	135 mm
QCF 200	200 mm	185 mm
QCF 250	250 mm	235 mm
QCF 300	300 mm	285 mm
QCF 350	350 mm	335 mm
QCF 380	380 mm	365 mm
QCF400	400 mm	385 mm
QCF500	500 mm	485 mm

## / ARTICULATED END CABLE CLEATS

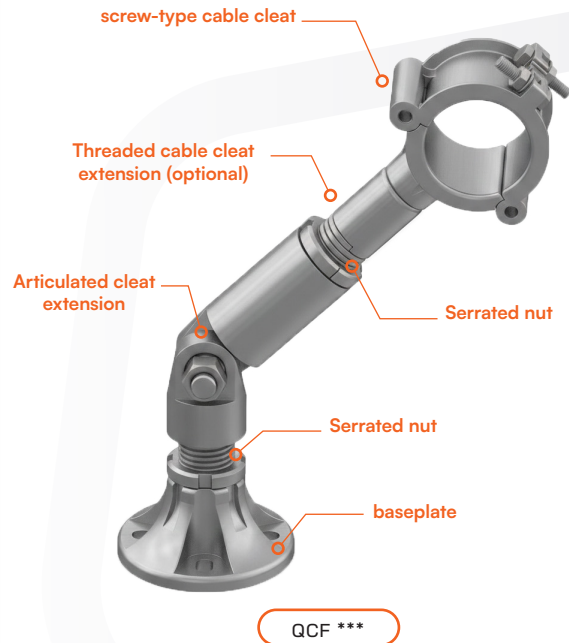

### / DESCRIPTION

The articulated cable cleat extension allows cable cleats to be positioned in any orientation. It can be combined with cable cleat extensions, screw-type cable cleats and baseplates, and is available in various configurations (M16 or M36).

### / MATERIAL

- AS7G06 aluminium alloy + stainless steel

### ✓ To be ordered separately

- Cable cleat, baseplates, nuts, threaded cable cleat extension, etc.

Reference	Connector's dimensions
QCA	
QCA-M16	
QCA-FF16	





## CABLE CLEATS & ACCESSORIES

### ALUMINIUM CABLE CLEATS

#### ACCESSORIES FOR ALUMINIUM CABLE CLEATS

Cable cleat support accessories enable easy installation in various configurations: direct mounting on the floor, wall or ceiling, or on a metal structure. They help meet specific constraints related to orientation and/or rigidity, as required in certain applications.

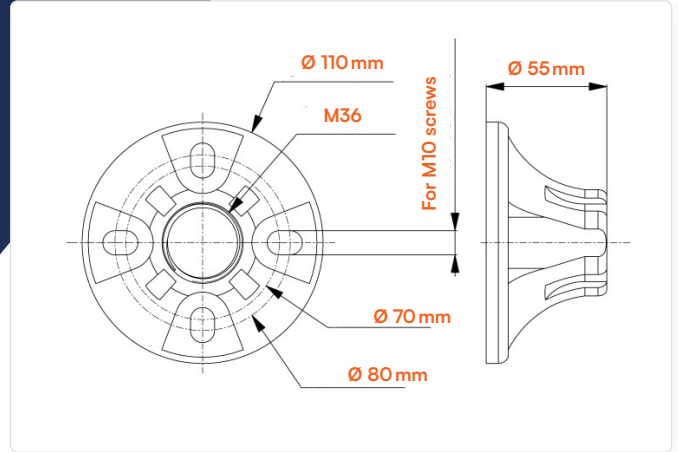
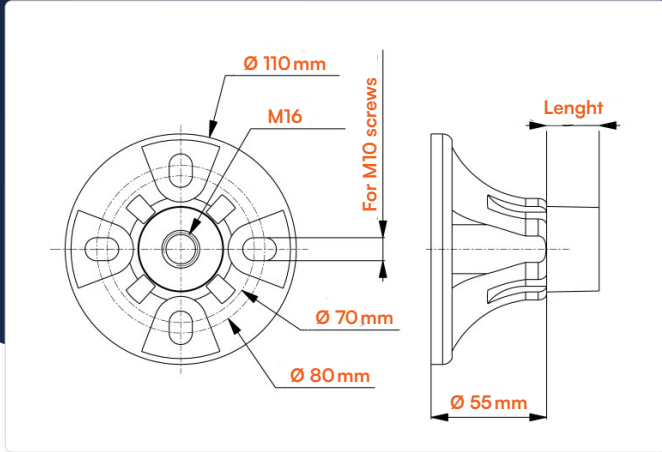

#### / BASEPLATE FOR CABLE CLEATS



##### / DESCRIPTION

The cleat baseplates is designed for direct mounting of single, double or triple screw-type cable cleats (M16). It is available in different lengths depending on the required cable clearance height.

##### / MATERIAL

- AS13 aluminium alloy

##### ⊕ To be ordered separately

- Fixing screwing: 4 M10 screw + 1 M16 serrated nut + 8 M10 washers + 4 M10 nuts (see page 51), M16 cleat.

Reference	Lenght
EQC 16/00	0 mm
EQC 16/00-V	
EQC 16/25	25 mm
EQC 16/50	50 mm

Longer lead times apply for baseplates with extensions.  
Use EQC36 with cable cleat extensions to increase height.

#### / BASEPLATES FOR END CABLE CLEATS



##### / DESCRIPTION

The cable cleat extension baseplates is designed for fixing an M36 threaded or articulated cable cleat extension (see page...).

##### / MATERIAL

- AS13 aluminium alloy

##### ⊕ To be ordered separately

- Fixing screwing: 4 M10 screw + 1 M36 serrated nut + 8 M10 washers + 4 M10 nuts (see page 23).
- Articulated or threaded cable cleat extension (see page 51).

Reference	Lenght
EQC 36	55 mm
EQC 36 V (fixing screwing included)	55 mm

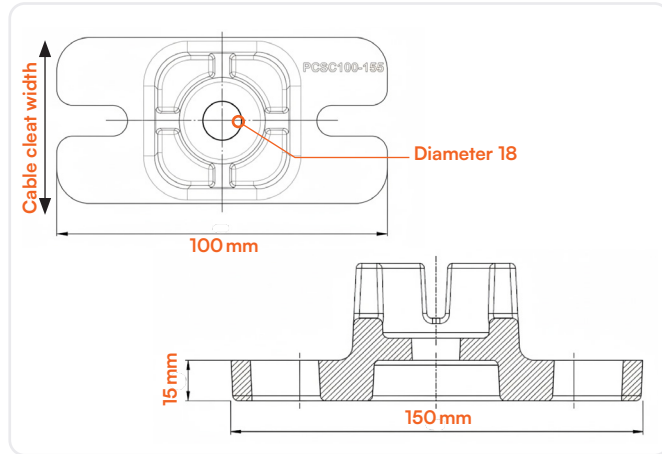
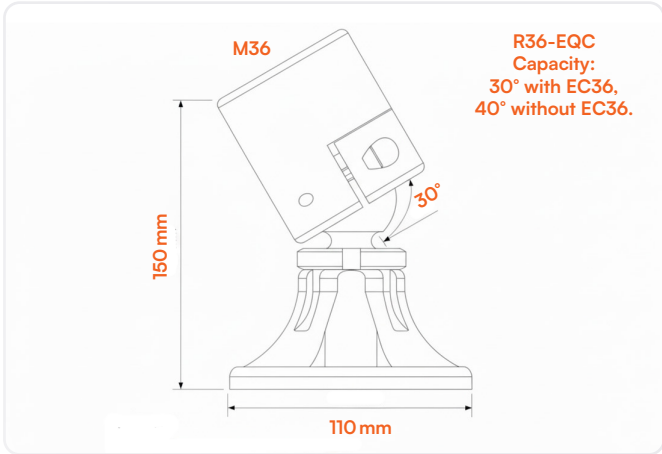

**/ BALL JOINT BASEPLATE**



R36-EQC

**/ DESCRIPTION**

The M36 ball joint with its baseplate (reference: [R36-EQC]) is used as a mounting baseplate for CSC cable cleats to support cables in any position.

**/ MATERIAL**

- AU4G aluminium alloy

**✓ Supplied with the cable cleat**

- Baseplate fixing using 4 M10 screws (see EQC baseplate)
- Ball joint tightening using 2 stainless steel M6 socket head cap screws, with position locking ensured by a stainless steel set screw
- Slip torque: 240 N-m (corresponding to slippage after applying a force of 192 kg at 125 mm from the spacing of the ball)

**⊕ To be ordered separately**

- Fixing screwing: 4 M10 screws + 1 M36 serrated nut + 8 M10 washers + 4 M10 nuts
- Articulated or threaded cable cleat extension

Reference	Length	Width	Height	Screwing
R36-EQC	110 mm	110 mm	150 mm	M36

**/ MOUNTING PLATE**

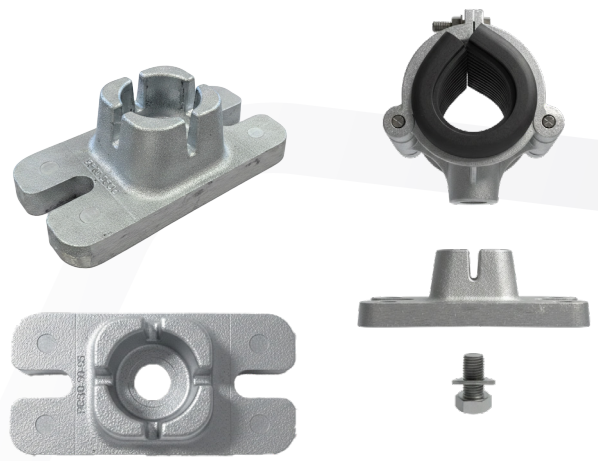

PCSC\*\*

**/ DESCRIPTION**

The PCSC mounting plate is designed to provide straight and secure fixing of CSC and CDC cable cleats, preventing rotation under cable tensile forces and short-circuit currents (ICC). It ensures quick and easy installation and can be fixed to the floor, wall or a support using two M12 screws.

Two versions are available:

- PCSC60-95: Compatible with CSC60 to CSC95 cable cleats
- PCSC100-155: Compatible with CSC100 to CSC155 cable cleats

**/ MATERIAL**

- AS7 aluminium + 316 stainless steel screwing

**✓ Supplied with the cable cleat**

- M16 stainless steel screw for nut-version cable cleat fixing

**⊕ To be ordered separately**

- M12 fixing screwing

Reference	Length	Width	Plate height only	Screwing spacing	Screwing
PCSC60-95-V	150 mm	75 mm	50 mm	100 mm	M16
PCSC100-155-V					



## CABLE CLEATS & ACCESSORIES

### ALUMINIUM CABLE CLEATS PROTECTIVE LINERS

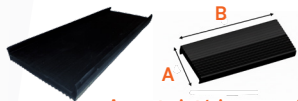
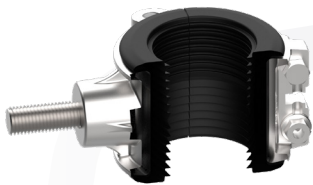

A : cote intérieure renforts

PCA\*\*

## / STANDARD LINERS

### / DESCRIPTION

- Standard liners ensure both support and protection of cables and are essential for proper cable cleat installation.
- Their shape is specifically designed to facilitate cable cleat closing and minimize cable slippage.
- They are pre-cut to match each cable cleat size and are inserted inside the cable cleat before closing.
- Cable cleats can be fully closed or tightened with a maximum torque of 22.6 Nm on stainless steel M8 screws and nuts with anti-seize treatment; no lubrication is required.

### / MATERIAL

- EPDM-PP

Numerous laboratory tests have been carried out to ensure the material meets required standards.

### + To be ordered separately

- Cable cleat

INFORMATION: Liner thickness: 8 or 10 mm, with a tolerance of  $\pm 0,6$  mm (average value at the bottom of the grooves)

Cable cleat type	Cable cleat reference	8 mm liner			10 mm liner		
		Réf.	A	B	Réf.	A	B
Single cable cleat	CS 44	PC 8-44	55 mm	120 mm	PC 10-44	55 mm	117 mm
	CS 47,5	PC 8-47,5	55 mm	131 mm	PC 10-47,5	55 mm	128 mm
Hinged single cable cleat	CSC 60	PCA 8-60	66 mm	172 mm	PCA 10-60	66 mm	165 mm
	CSC 65	PCA 8-65	66 mm	188 mm	PCA 10-65	66 mm	180 mm
	CSC 70	PCA 8-70	66 mm	203 mm	PCA 10-70	66 mm	196 mm
	CSC 75	PCA 8-75	66 mm	219 mm	PCA 10-75	66 mm	212 mm
	CSC 80	PCA 8-80	80 mm	235 mm	PCA 10-80	80 mm	228 mm
	CSC 85	PCA 8-85	80 mm	250 mm	PCA 10-85	80 mm	243 mm
	CSC 90	PCA 8-90	80 mm	266 mm	PCA 10-90	80 mm	259 mm
	CSC 95	PCA 8-95	80 mm	282 mm	PCA 10-95	80 mm	275 mm
	CSC 100	PCA 8-100	100 mm	297 mm	PCA 10-100	100 mm	290 mm
	CSC 105	PCA 8-105	100 mm	313 mm	PCA 10-105	100 mm	306 mm
	CSC 110	PCA 8-110	100 mm	329 mm	PCA 10-110	100 mm	322 mm
	CSC 115	PCA 8-115	100 mm	345 mm	PCA 10-115	100 mm	337 mm
	CSC 120	PCA 8-120	100 mm	360 mm	PCA 10-120	100 mm	353 mm
	CSC 125	PCA 8-125	100 mm	376 mm	PCA 10-125	100 mm	369 mm
	CSC 130	PCA 8-130	100 mm	392 mm	PCA 10-130	100 mm	385 mm
	CSC 135	PCA 8-135	100 mm	407 mm	PCA 10-135	100 mm	400 mm
CSC 140	PCA 8-140	100 mm	423 mm	PCA 10-140	100 mm	416 mm	
CSC 145	PCA 8-145	100 mm	439 mm	PCA 10-145	100 mm	432 mm	
CSC 155	PCA 8-155	100 mm	470 mm	PCA 10-155	100 mm	463 mm	
Hinged double cable cleat	CDC 60	PCD 8-60	78 mm	345 mm	PCD 10-60	78 mm	340 mm
	CDC 66	PCD 8-66	76 mm	387 mm	PCD 10-66	76 mm	380 mm
Triple cable cleat	CST 60	PCT 8-60	80 mm	172 mm	PCT 10-60	80 mm	165 mm
	CST 65	PCT 8-65	80 mm	188 mm	PCT 10-65	80 mm	180 mm
	CST 70	PCT 8-70	80 mm	203 mm	PCT 10-70	80 mm	196 mm
	CST 75	PCT 8-75	80 mm	219 mm	PCT 10-75	80 mm	212 mm
	CST 80	PCT 8-80	80 mm	235 mm	PCT 10-80	80 mm	228 mm
	CST 85	PCT 8-85	80 mm	250 mm	PCT 10-85	80 mm	243 mm
Hinged triple cable cleat	CTSI 65	PCA 8-65	66 mm	188 mm	PCA 10-65	66 mm	180 mm
	CTSI 85	PCA 8-85	80 mm	250 mm	PCA 10-85	80 mm	243 mm
	CTSI 90	PCA 8-90	80 mm	266 mm	PCA 10-90	80 mm	259 mm
	CTSI 100	PCA 8-100	100 mm	297 mm	PCA 10-100	100 mm	290 mm
	CTSI 110	PCA 8-110	100 mm	329 mm	PCA 10-110	100 mm	322 mm
CTSI 115	PCA 8-115	100 mm	345 mm	PCA 10-115	100 mm	337 mm	



## / LINERS FOR 3 CABLES



EPDM liner

PCA\*\*

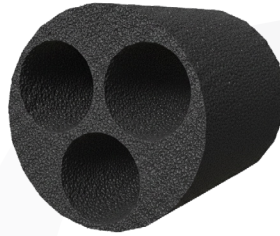

Three-phase foam liner

FDT\*\*



Installation example  
with EPDM liner

### / DESCRIPTION

Liners for 3 cables allow three cables to be secured within a hinged single cable cleat.

Two types are available:

- Trefoil liner: designed for fastening three single-core cables. Each cable is separated by a foam partition.
- 3-cable liner: designed for fastening three single-core cables or three twisted cables.

### / MATERIAL

- Trefoil liner: foam
- 3-cable liner: EPDM-PP

### + To be ordered separately

- Hinged single cable cleat (see page 12)

Liner reference	Associated cable cleat	Diameter of each cable	Cable spacing
FDT3080	CSC80	30 mm	36 mm
FDT3790	CSC90	37 mm	41 mm
FDT3990	CSC90	39 mm	43 mm
FDT40105	CSC105	40 mm	50 mm
FDT47125	CSC125	47 mm	58 mm
FDT50125	CSC125	50 mm	58 mm

Protection reference	Associated cable cleat	Cable cross-section (each)	Cable voltage	Cable standard
PCA 8-75	CSC 75	50 mm <sup>2</sup>	12/20 kV	C33-226
PCA 8-80	CSC 80	95 mm <sup>2</sup>		
PCA 10-85	CSC 85	150 mm <sup>2</sup>		
PCA 8-90	CSC 90	240 mm <sup>2</sup>		



Slip test carried out on CSC + PCA



Hex driver 13  
(6-point)



CAD

## / SOCKET WRENCH

### / DESCRIPTION

The socket wrench is designed for all hinged cable cleats. It allows the covers of the hinged cable cleats to be connected with a minimum effort and time. Once the socket wrench is in place, the cable cleat remains securely held on its own, freeing the operator from any additional handling.



The socket wrench is used with a hex wrench of 13 that is fastened on the hex driver.

### / Instructions for use with hinged cable cleats

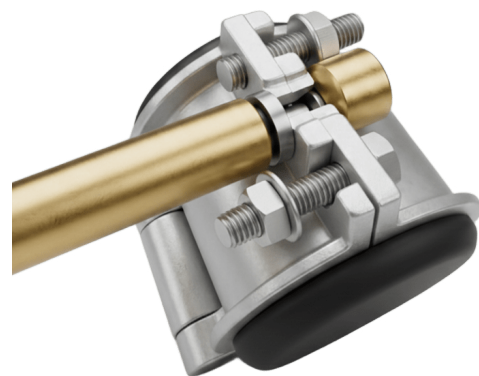



## / PIN WRENCH

### / DESCRIPTION

The pin wrench is designed for screws, castellated nuts, sets of insulation connectors as well as for all hinged ALROC cable cleats less than 80 mm. It allows the covers of the hinged cable cleats to be connected with a minimum force and time.



- Used on M8 screws, M8 nuts and castellated M16 or M36 nuts.
- For cable cleats bigger than 80 mm, we advise using the CAD socket wrench.

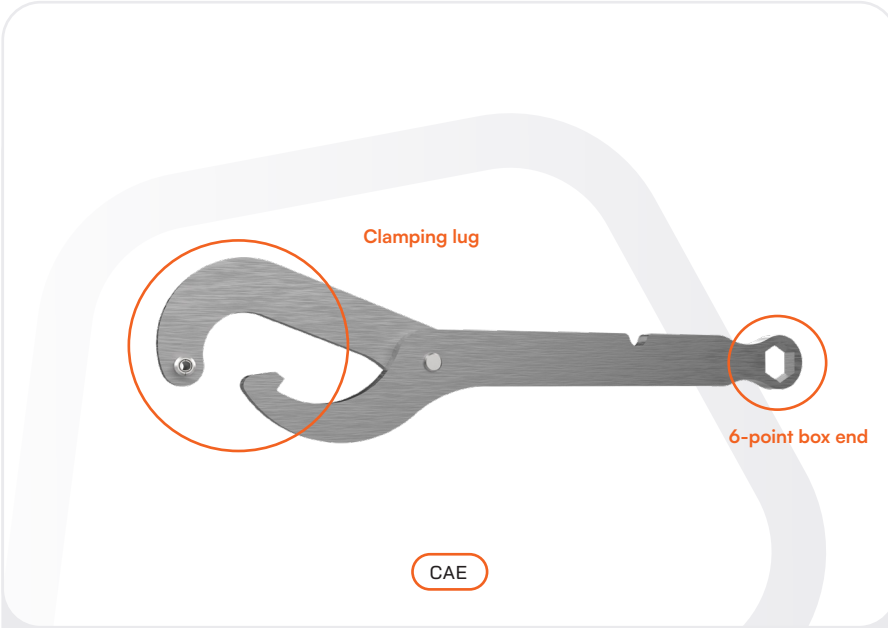

### / Instructions for use with hinged cable cleats

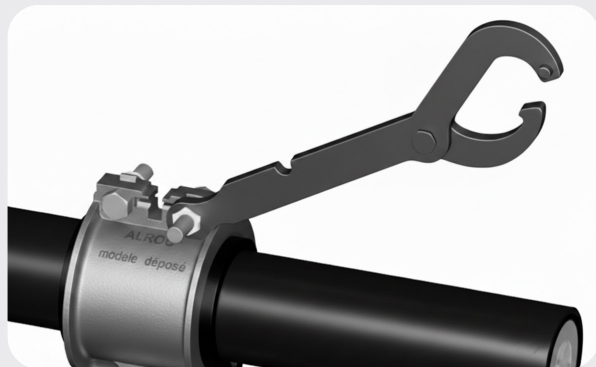
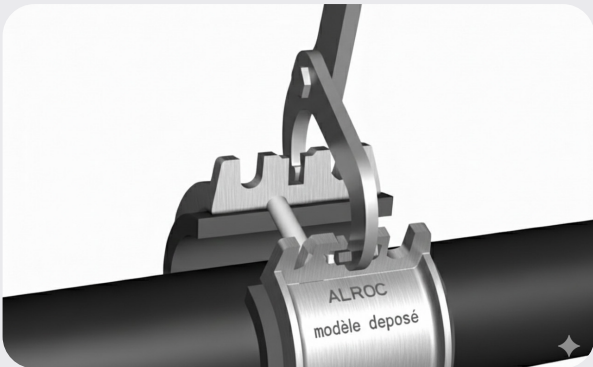

### / Instructions for use with insulating links (ELI)

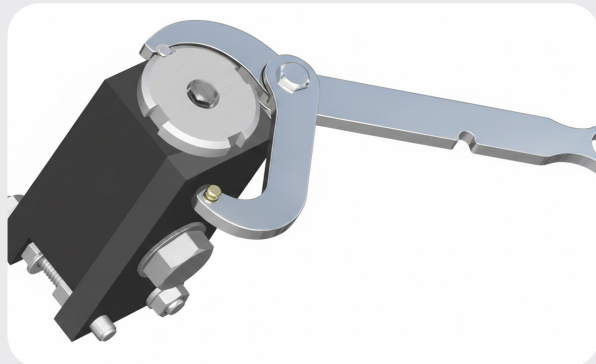
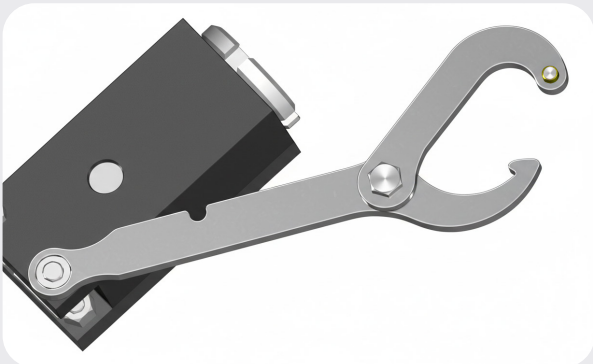



Your life,  
**Our work.**



# STRAP CABLE CLEATS

## **/ Intermediary strap cable cleats** **32**

Simplified intermediary cable cleat

Intermediary cable cleat

## **/ Suspended strap cable cleats** **34**

Strap cable cleats suspended from capstan-headed screw

Spiral suspended strap cable cleats

Suspended strap cleat with chain

Eyelet suspended strap cable cleats

## **/ Shoe** **38**

Plastic saddle

Aluminium saddle

## **/ Suspended strap cable cleats** **40**

Y-cleat

## **/ Special / custom supports** **41**

Custom saddle

Floor fixing cable cleats



## CABLE CLEATS & ACCESSORIES

### STRAP CABLE CLEATS

#### INTERMEDIARY STRAP CABLE CLEATS

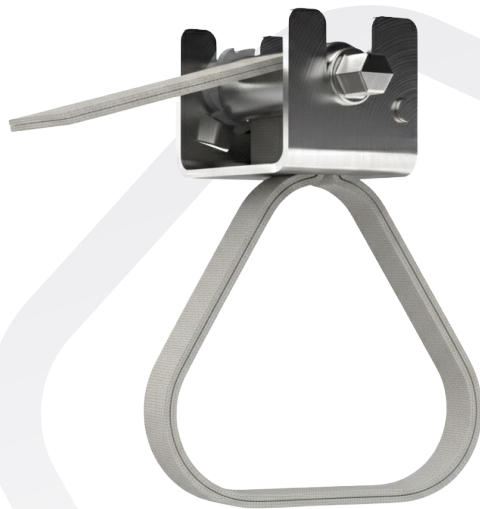

## / SIMPLIFIED INTERMEDIARY CABLE CLEAT

### / DESCRIPTION

- The simplified intermediate strap cable cleat allows three cables to be secured together and/or one or more cables to be fixed onto a cable ladder.
- The simplified intermediate strap cable cleat has not undergone mechanical resistance testing and is therefore recommended for applications where no mechanical constraints need to be considered.

### / MATERIAL

- Stainless steel + aluminium
- Strap: HR polyester, UV-resistant and flame-retardant / breaking strength: 2000 daN (40 mm) and 4000 daN (80 mm).

CE21\*\*

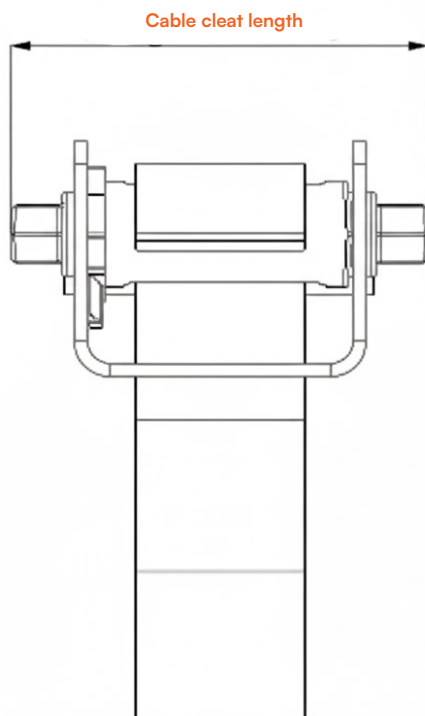

Cable cleat length

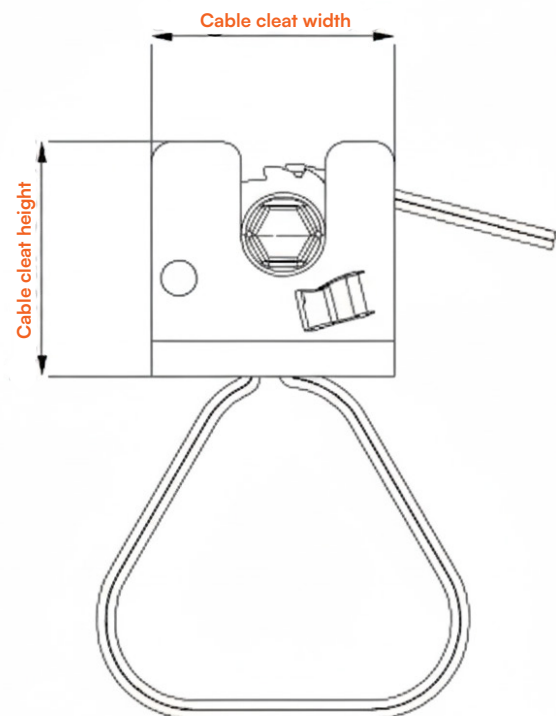

Cable cleat width

Cable cleat height

Cable cleat reference	Cable Ø (each phase)	Cable cleat length	Cable cleat height	Cable cleat width	Strap length	Strap width
CE2140/120	30 to 38 mm	95 mm	53 mm	55 mm	120 mm	40 mm
CE2140/140	38 to 55 mm				140 mm	
CE2140/160	55 to 71 mm				160 mm	
CE2140/180	71 to 88 mm				180 mm	



## / INTERMEDIARY CABLE CLEAT

### / DESCRIPTION

Intermediate strap cable cleats are designed to secure three cables in a trefoil arrangement and to withstand forces generated by short circuits. They are manufactured from non-corrosive materials and are compliant with and tested according to IEC 61914 (see IEC table, pages 52–53).

### / MATERIAL

- Non-corrosive materials
- Cable cleat: aluminium + stainless steel
- Strap: HR polyester, UV-resistant and flame-retardant / breaking strength: 2000 daN (40 mm) and 4000 daN (80 mm)

### ✓ Supplied with the cable cleat

- M16 closing screwing



Strap tightening is performed using a ratchet system and locked at the end of installation

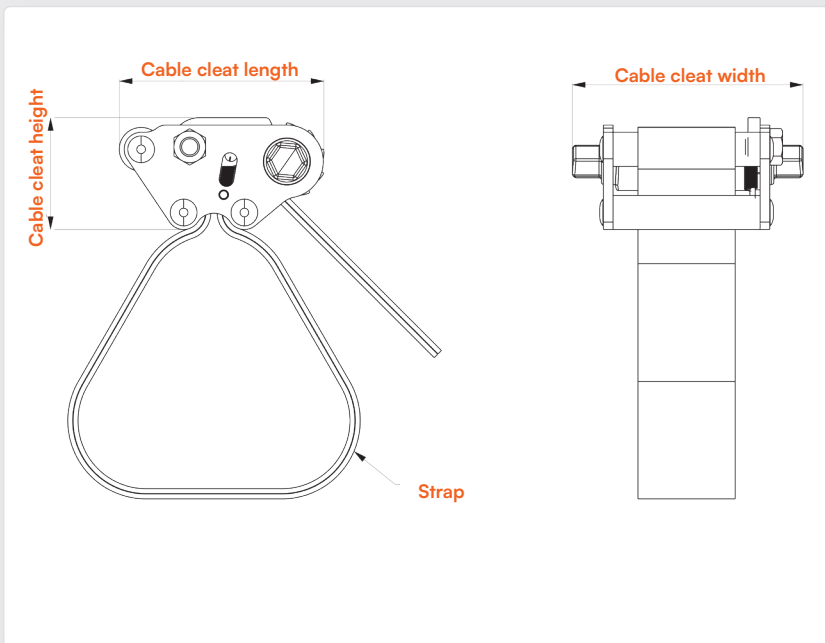

Cable cleat reference	Cable Ø (each phase)	Cable cleat length	Cable cleat width	Strap length	Strap width
CS2140/120	30 to 38 mm	83 mm	95 mm	120 mm	40 mm
CS2140/140	38 to 55 mm			140 mm	
CS2180/140			130 mm	150	80 mm
CS2180/150	55 to 63 mm				
CS2140/160	63 to 71 mm		95 mm	160 mm	40 mm
CS2180/160			130 mm		
CS2180/180	71 to 88 mm		130 mm	180	80 mm
CS2140/200	88 to 105 mm				
CS2180/200			130 mm	200 mm	80 mm
CS2140/220	105 to 121 mm		95 mm		
CS2180/220			130 mm		
CS2140/250	121 to 146 mm		95 mm	250 mm	40 mm
CS2180/250			130 mm		



## CABLE CLEATS & ACCESSORIES

### STRAP CABLE CLEATS SUSPENDED STRAP CABLE CLEATS



Strap tightening is performed using a ratchet system and locked at the end of installation.



CSI\*\*

## / STRAP CABLE CLEATS SUSPENDED FROM CAPS-TAN-HEADED SCREW

### / DESCRIPTION

Suspended strap cable cleats with eye screws can be fixed to various supports (e.g. brackets, structures, etc.), providing a high degree of freedom of movement. They are ideal for rotation parallel to the cable axis.

Tested and compliant with IEC 61914, they are designed to withstand forces generated by short circuits.

### / MATERIAL

- Non-corrosive materials
- Cable cleat: aluminium + stainless steel
- Stem: M12 stainless steel
- Strap: HR polyester, UV-resistant and flame-retardant / breaking strength: 2000 daN (40 mm) and 4000 daN (80 mm)

### + To be ordered separately

- Mounting bracket (see pages 44–45)

Cable cleat length

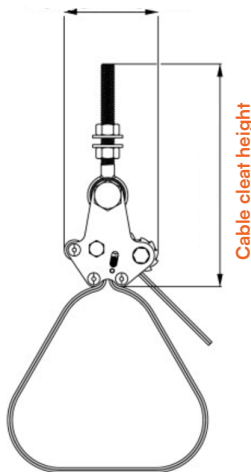

Cable cleat width

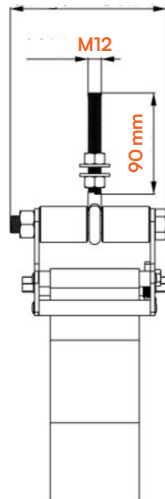

Cable cleat reference	Cable Ø (each phase)	Cable cleat length	Cable cleat width	Cable cleat height	Strap width
CSI40/100	10 to 21 mm	83 mm	110 mm	200 mm	40 mm
CSI40/110	21 to 30 mm				
CSI40/120	30 to 38 mm		90 mm		20 mm
CSI40/140	38 to 55 mm		110 mm		40 mm
CSI80/140			150 mm		80 mm
CSI40/160	55 to 71 mm		110 mm		40 mm
CSI80/160			150 mm		80 mm
CSI40/180	71 to 88 mm		110 mm		40 mm
CSI80/180			150 mm		80 mm
CSI40/200	88 to 105 mm		110 mm		40 mm
CSI80/200			150 mm		80 mm
CSI80/220	105 to 121 mm		110 mm		40 mm
CSI80/250	121 to 146 mm		150 mm		80 mm





Strap tightening is performed using a ratchet system and locked at the end of installation.

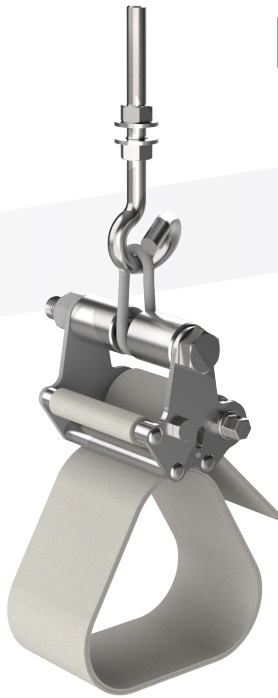

CSI\*\*-QC12

## / SPIRAL SUSPENDED STRAP CABLE CLEATS

### / DESCRIPTION

Suspended strap cable cleats with pigtail hooks can be fixed to various supports (e.g. brackets, structures, etc.) to support cables and allow rotation of the cable cleat both parallel and perpendicular to the cable axis. They are designed to withstand forces generated by short circuits and are tested and compliant with IEC 61914.

### / MATERIAL

- Non-corrosive materials
- Cable cleat: aluminium + stainless steel
- Stem: M12 stainless steel
- Strap: HR polyester, UV-resistant and flame-retardant / breaking strength: 2000 daN (40 mm) and 4000 daN (80 mm)

### + To be ordered separately

- Mounting bracket (see pages 44–45)

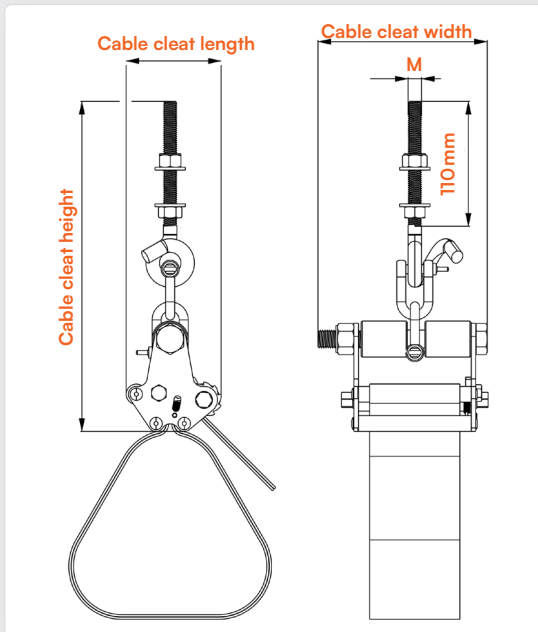

Cable cleat reference	Cable Ø (each phase)	Cable cleat length	Cable cleat width	Strap width	Strap length	Thread (M)
CSI80/160-QC12	63 to 71mm	83mm	300 mm	80 mm	160 cm	M12
CSI80/180-QC12	71 to 88mm				180 cm	
CSI80/200-QC10	88 to 105 mm				200 cm	M10
CSI80/200-QC12	88 to 105 mm				220 cm	
CSI80/220-QC12	105 to 121mm				250 cm	
CSI80/250-QC12	121 to 145 mm					



## CABLE CLEATS & ACCESSORIES

### STRAP CABLE CLEATS SUSPENDED STRAP CABLE CLEATS



Pigtail hook with M12 expansion anchor  
Reference: QCE12x110

Stainless steel chain  
Links: 52 x 16 mm  
Wire diameter: 8 mm  
The chain can be cut to the desired length (sold per linear meter)  
Reference: 105/CH16528i

Stainless steel quick link Ø7  
Optional  
Reference: 115/AC001

M12 stainless steel tensioner  
2 rings  
Adjustment range: 260 to 430 mm  
Optional  
Approximate load: 1,200 kg  
Reference: T260-M12i

Strap cable cleat for chain  
Reference in the table below

CSI\*\*-CH

## / SUSPENDED STRAP CABLE CLEAT WITH CHAIN

### / DESCRIPTION

Suspended strap cable cleats with chain allow one or more cables to be supported from the ceiling, offering a high degree of freedom of movement thanks to this fixing system.

#### + To be ordered separately

- Pigtail hook: QCE12x110
- Stainless steel chain: 105/CH16528i
- Quick link: 115/AC001
- Tensioner: T260-M12i



Accessories are sold separately

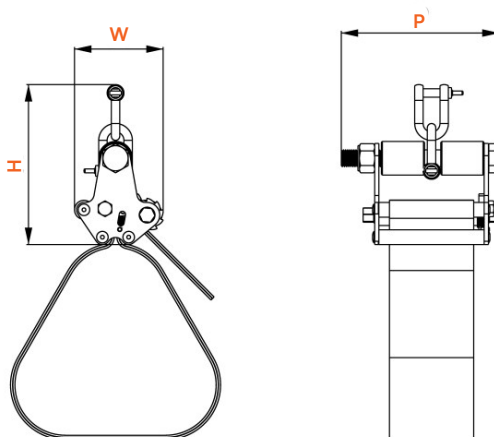

Cable cleat reference	Cable Ø (each phase)	Cable cleat length (W)	Cable cleat width (P)	Cable cleat height (H)	Strap length	Strap width
CSI40/140-CH	55 mm	83 mm	95 mm	144 mm	140 mm	40 mm
CSI80/140-CH		82 mm	140 mm		180 mm	80 mm
CSI80/180-CH	105 mm				200 mm	
CSI80/200-CH						

Longer strap lengths available on request.



For enhanced strength, the strap is seamless and reinforced at the four 10 mm holes, which are heat-punched.



## / EYELET SUSPENDED STRAP CABLE CLEATS

### / DESCRIPTION

Suspended strap cable cleats with eyelets are used to suspend NFC33-226 12/20 kV cables assembled in a twisted configuration. These cable cleats are not designed to withstand short-circuit forces.

### / MATERIAL

- Non-corrosive materials
- Shackle: stainless steel
- Stem: M12 stainless steel
- Strap: HR polyester, UV-resistant and flame-retardant / breaking strength: 2000 daN (40 mm)
- Maximum load: 150 daN



CAO40\*\*

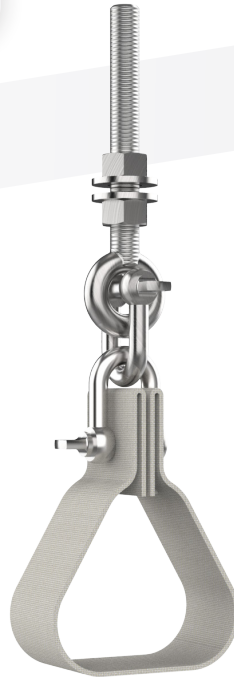

CAO40\*\*-M12X90

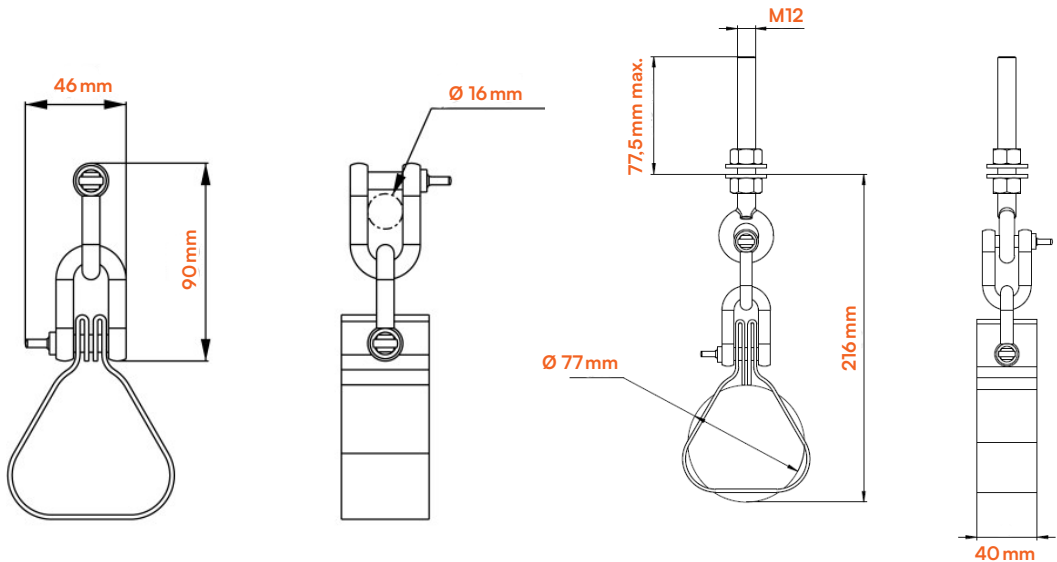

Cable cleat reference	Cable cross-section (each phase)	Cable cleat length	Cable cleat width	Strap width	Maximum load
CAO40/3x95-2	10 <sup>2</sup> to 240 <sup>2</sup> mm	46 mm	90 mm	40 mm	150 kg
CAO40/3x150-2					
CAO40/3x240-2					
CAO40-3-240-2-M12x90		216 mm			

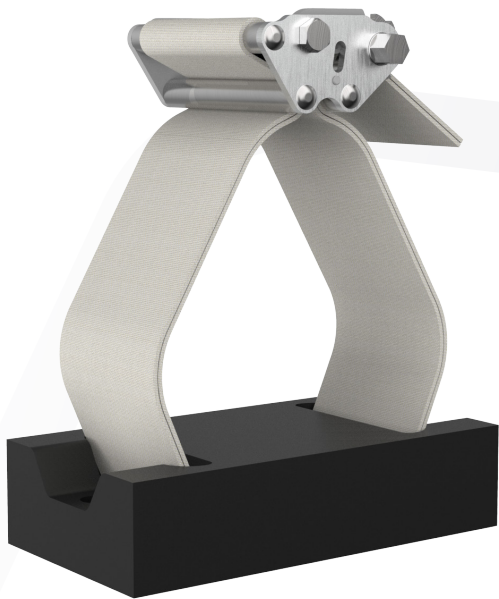

SCS\*\*

## / PLASTIC CABLE SADDLES

### / DESCRIPTION

- The plastic saddle is designed to support horizontal cables (or with a slight slope <math><30^\circ</math>). It can be used for three-core cables (trefoil arrangement) or single-core cables. The support is fixed directly to the floor or to structures
- High corrosion resistance
- No grounding required
- Strap cable cleat compliant with IEC 61914

### / MATERIAL

- Saddle: HDPE (high-density polyethylene)
- Screwing: stainless steel

### + To be ordered separately

- Intermediate strap cable cleat (see page 33)

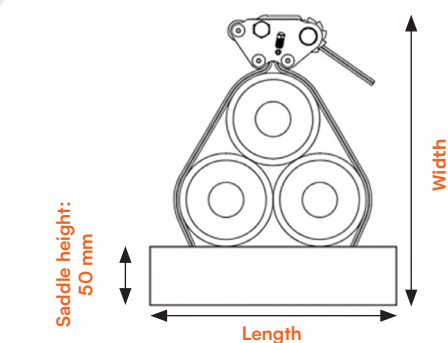
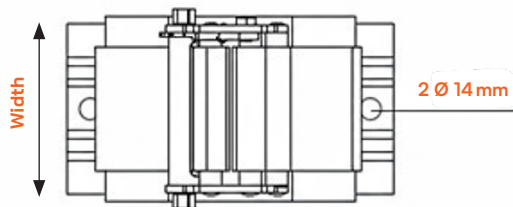

Reference	Associated strap cable cleat	Cable Ø (trefoil)	Cable Ø (1 phase)	Length	Width	Height	Spacing
SCS-30	CS2140/140	25 to 45 mm	45 to 80 mm	140 mm	110 mm	225 mm	110 mm
SCS-60	CS2180/160	45 to 60 mm	90 to 120 mm	180 mm		265 mm	150 mm
SCS-80	CS2180/180	60 to 90 mm	120 to 155 mm	210 mm		320 mm	180 mm
SCS-100	CS2180/220	80 to 120 mm	155 to 200 mm	245 mm		330 mm	215 mm



SCS\*\*-\*\*

## / ALUMINIUM SADDLES

### / DESCRIPTION

Aluminium saddles are designed to support horizontal cables (or with a slight slope <math><30^\circ</math>) arranged in a trefoil configuration. They are fixed directly to the floor or to structures. The support is designed to hold three cables in position during strap installation and cable cleat tightening.

### / MATERIAL

- Saddle: AS7G06 aluminium alloy
- Protection: EPDM-PP rubber
- Cable cleat: stainless steel

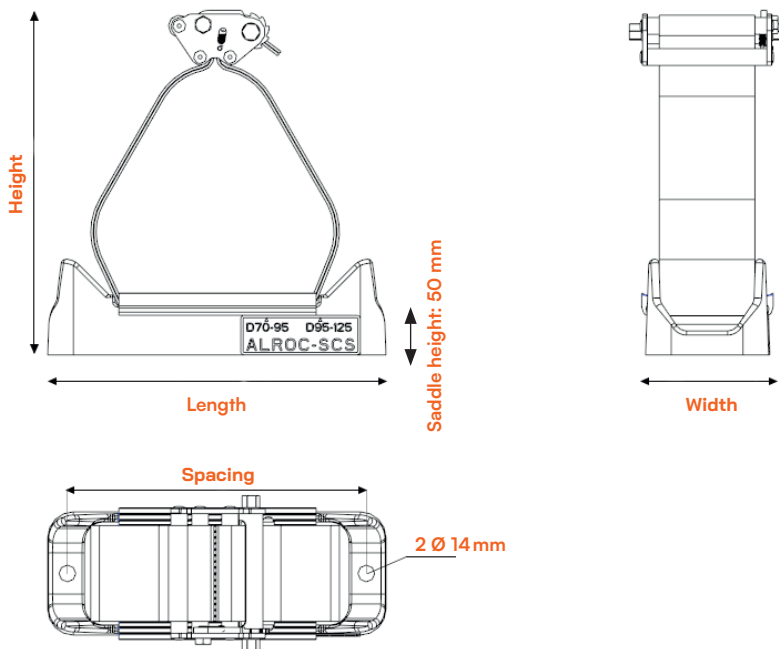

Reference	Cable dimensions	Length	Width	Height	Spacing
SCS-70-85	70 to 85 mm	260 mm	280 mm	100 mm	250 mm
SCS-85-105	85 to 105 mm	300 mm			
SCS-105-125	105 to 125 mm	335 mm			



CABLE CLEATS & ACCESSORIES

STRAP CABLE CLEATS  
SUSPENDED STRAP CABLE CLEATS



CSY\*\*V

CSY\*\*E

/ Y-CABLE CLEAT FOR  
CABLE JUNCTIONS

/ DESCRIPTION

The Y-cable cleat is designed to support cables, joints or large-diameter ducts.

It can be fixed onto a joint support frame, a baseplate, or a cable cleat extension. The screwing can be adapted according to requirements.

/ MATERIAL

- Cable cleat: AS13 aluminium alloy + stainless steel components
- Strap: HR polyester, UV-resistant and flame-retardant / breaking strength: 4000 daN

✓ Supplied with the cable cleat

- Closing screwing

⊕ To be ordered separately

- Fixing screwing (see page 51)

The Y-cable cleat can be mounted on a baseplate or a cable cleat extension (see pages 23 to 25).



Strap tightening is performed using a ratchet system and locked at the end of installation.

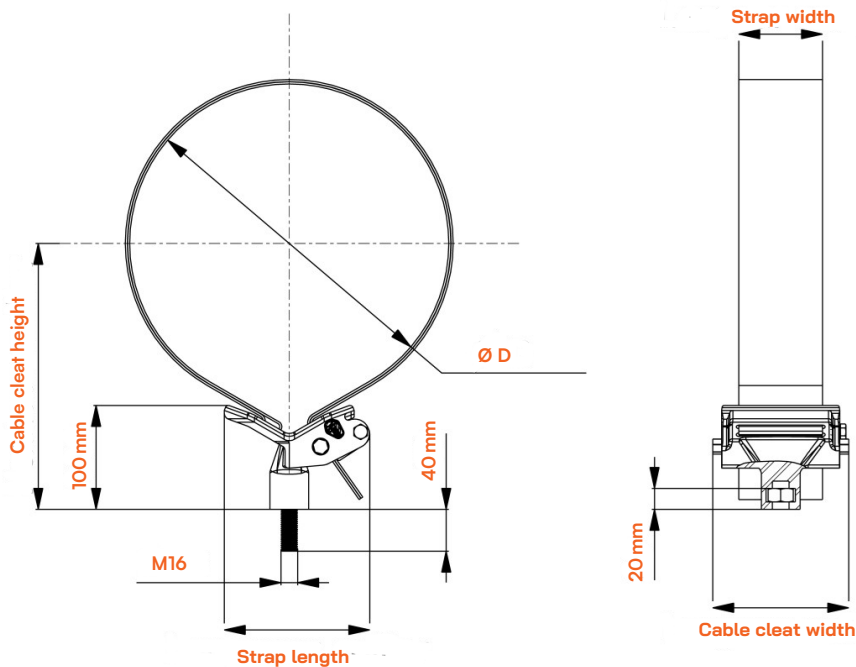

Reference		$\varnothing D$	Cable cleat length	Cable cleat width	Cable cleat height	Strap length	Strap width
M16 screw	M16 nut						
CSY 80V/180	CSY 80E/180	250 mm	140 mm	130 mm	220 mm	180 mm	80 mm
CSY 80V/300	CSY 80E/300	430 mm			320 mm	300 mm	

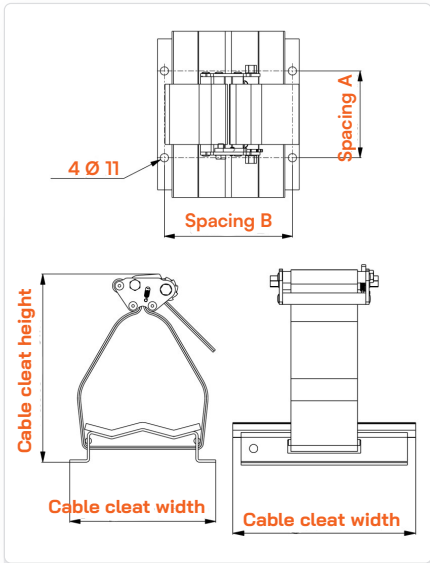

S\*\* -CS2I

Saddle sized according to cable diameter

## / TAILOR-MADE CABLE SADDLES

### / DESCRIPTION

The saddle is used for floor-mounted installations where single-phase cables, joints or PVC ducts are arranged in a trefoil configuration. The cables rest on a protective liner and are secured to a stainless steel plate using an intermediate strap cable cleat (supplied).

### / MATERIAL

- Cable cleat: AS13 aluminium alloy + stainless steel components
- Strap: HR polyester, UV-resistant and flame-retardant / breaking strength: 4000 daN

### ✓ Supplied with the cable cleat

- Protection between the cables and the stainless steel plate
- Closing screwing

### + To be ordered separately

- Fixing screwing (4 M10 screws) (see page 51)
- Grounding clamp (dedicated location provided) (see page 50)

Reference	Spacing		Cable Ø (each phase)	Cable cleat length	Cable cleat width	Cable cleat height	Strap length
	A	B					
S80-CS2I 80/180	115 mm	170 mm	80 mm	188 mm	200 mm	243 mm	180 mm
S95-CS2I 80/200		198 mm	95 mm	216 mm		268 mm	200 mm
S100-CS2I 40/200		210 mm	100 mm	228 mm		275 mm	
S120-CS2I 80/220		225 mm	120 mm	273 mm		318 mm	220 mm

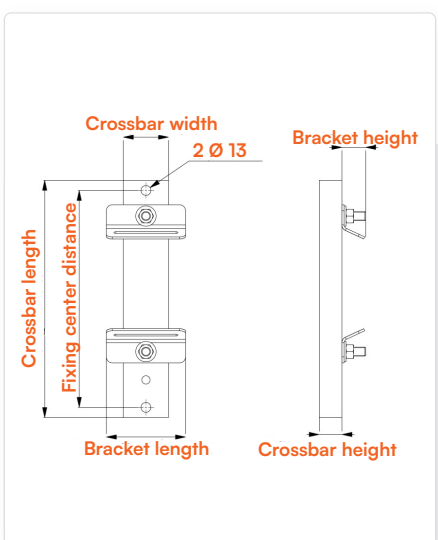

EAS\*\*

## / FLOOR BRACKET

### / DESCRIPTION

The floor bracket is designed to support two or three cables horizontally in a trefoil arrangement. The hot-dip galvanized steel crossbar is fitted with two stainless steel brackets. It can also be used to support joints, PVC ducts or other components. Custom versions are available on request.

### / MATERIAL

- Crossbar: hot-dip galvanized steel
- Brackets and screwing: stainless steel

### ✓ Supplied with the bracket

- Stainless steel screwing for bracket fixing

### + To be ordered separately

- Intermediate strap cable cleat with 40 mm or 80 mm strap width (see page 33)
- Grounding clamps (11 mm diameter hole provided) (see page 50)

Reference	Associated strap cable cleat (not supplied)	Fixing screw spacing	Bracket height	Crossbar height	Crossbar width	Crossbar length	Cable Ø (1 phase, mm)
EAS40-110-288	CS2140/160	288 mm	31.5 mm	30 mm	60 mm	315 mm	45 to 55 mm
EAS80-110-288	CS2180/160						
EAS40-130-308	CS2140/160	308 mm				335 mm	55 to 65 mm
EAS80-130-308	CS2180/160						
EAS80-150-328	CS2180/180	328 mm				375 mm	65 to 75 mm
EAS80-170-348	CS2180/180	348 mm					
EAS80-190-368	CS2180/200	368 mm	395 mm	75 to 85 mm			
						85 to 95 mm	



Your life,  
Our work.



# METAL SUPPORTS

<b>/ Standard brackets</b>	<b>44</b>
Insulating bracket	
Metal bracket	
<b>/ Adjustable trestles</b>	<b>46</b>
<b>/ Support posts</b>	<b>46</b>
<b>/ Tailored mounting solutions</b>	<b>46</b>
<b>/ Other installation examples</b>	<b>47</b>



## / INSULATING BRACKET



PI-190-A

### / DESCRIPTION

The insulated bracket is designed to suspend one or more cables. It is used in combination with one or more suspended strap cable cleats. This bracket is suitable for all environments, including corrosive ones, and does not require grounding.

### / MATERIAL

- Epoxy insulating resin

### ✓ Supplied with the bracket

- Suspended strap cable cleat (see pages 34–36)
- Fixing screwing (see page 51)



MV and HV applications

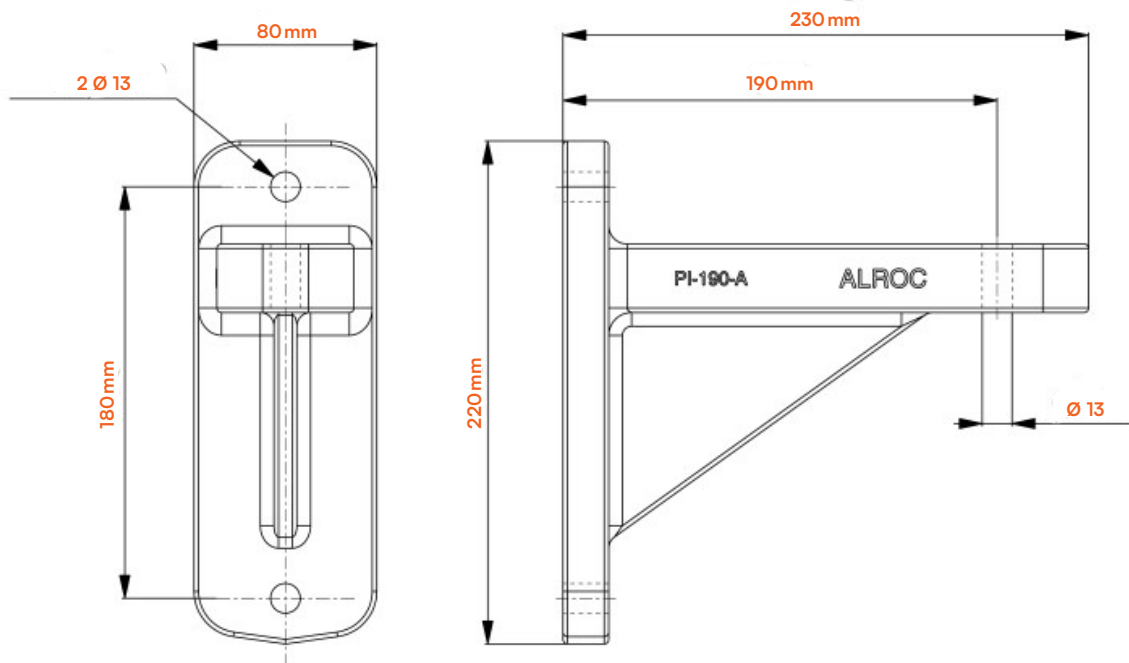

Reference	Bracket length	Bracket width	Bracket height	Fixing spacing	Cable position	Ø V
PI-190-A	230 mm	80 mm	220 mm	180 mm	190 mm	1 hole Ø13



CS-250-200-14

## / METAL BRACKET

### / DESCRIPTION

The metal bracket is designed to suspend one or more cables. It is used in combination with a suspended strap cable cleat or a hinged cable cleat.

This bracket is hot-dip galvanized for corrosion protection. Grounding is required, with a dedicated lug provided for the grounding clamp.

### / MATERIAL

Hot-dip galvanized steel

### + To be ordered separately

- Suspended strap cable cleat (see pages 34–36)
- Hinged cable cleat (see page 18)
- Fixing screwing (see page 51)
- Grounding clamp (see page 50)



MV and HV applications

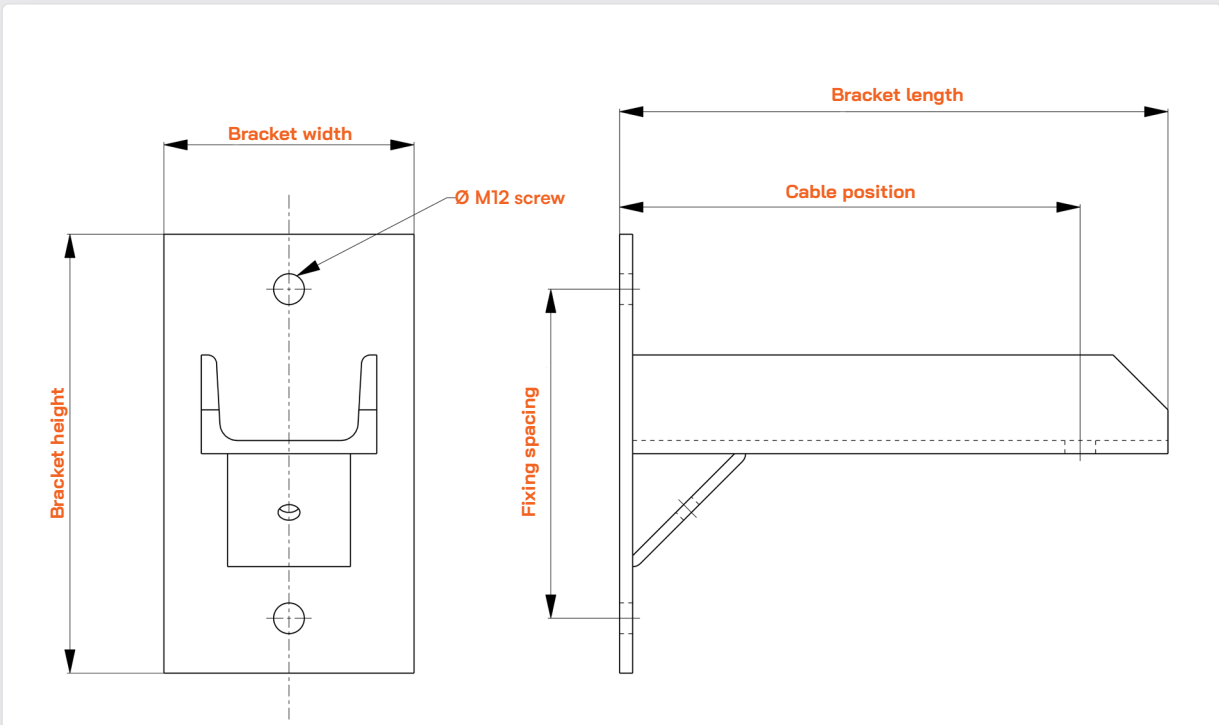

Reference	Bracket length	Bracket width	Bracket height	Fixing spacing	Cable position	Ø V
CS-250-200-14	250 mm	80 mm	190 mm	200 mm	200 mm	1 hole Ø13

Custom brackets available on request.



## CABLE CLEATS & ACCESSORIES

### METAL SUPPORTS

### CUSTOM BRACKETS & ADJUSTABLE TRESTLES



TRV\*\*

## / ADJUSTABLE TRESTLES

### / DESCRIPTION

- Adjustable metal frames are designed to accommodate single or triple cable cleats, as well as strap cable cleats, in order to support single-core or three-core cables.
- Depending on the model, the frames are adjustable in width and/or height.

### / MATERIAL

- Trestle: hot-dip galvanized steel
- Screwing: stainless steel

### ✓ Supplied with the trestle

- Hardware (see page 51)
- Plastic end caps for square tubes
- Grounding clamp (see page 50)

### ⊕ To be ordered separately

- Floor fixing system
- Suspended strap cable cleat (see pages 34–36)
- Single cable cleat (see page 12)
- Triple cable cleat (see page 16)

Reference	Description	TRV	RH
TRV400 - RH700	Adjustable trestles 400x700	400 mm	700 mm
TRV400 - RH1200	Adjustable trestles 400x1200		1200 mm
TRV700 - RH700	Adjustable trestles 700x700	700 mm	700 mm
TRV700 - RH1200	Adjustable trestles 700x1200		1200 mm
TRV1200 - RH700	Adjustable trestles 1200x700	1200 mm	700 mm
TRV1200 - RH1200	Adjustable trestles 1200x1200		1200 mm

## / SUPPORT POSTS

Support posts are essential elements for fixing brackets or cable cleats.

Designed to adapt to a wide range of environments and constraints, they offer great installation flexibility thanks to various height options, ranging from 50 cm up to 3 meters or more, depending on specific project requirements.

To ensure optimal stability, support posts can be reinforced with crossbars, providing additional rigidity when loads or operating conditions require it, and can even be anchored to the ceiling.

Each post is equipped with a wide and robust baseplate featuring four anchoring points, ensuring secure and durable installation.

Whether for standard projects or custom solutions, our support posts are designed to meet the most stringent safety requirements and are engineered with a high safety margin in terms of strength.

## / TAILORED MOUNTING SOLUTIONS

Our support posts offer great installation flexibility and can be combined with crossbars to meet the specific constraints of each project and create cable routing structures.

Thanks to the extensive experience of our Design Office and a wide range of solutions and accessories, a large variety of configurations can be achieved.

Available options include, in particular, installations beneath transformers, with adjustable heights. Each project can be entrusted to our Design Office (BE) to develop an optimized, tailor-made solution.

Whether for cable support, current transformers, joints, constrained bending radii, complex routing, structural enclosures, or any other specific requirements, our team is at your disposal to study, model and design a customized solution.

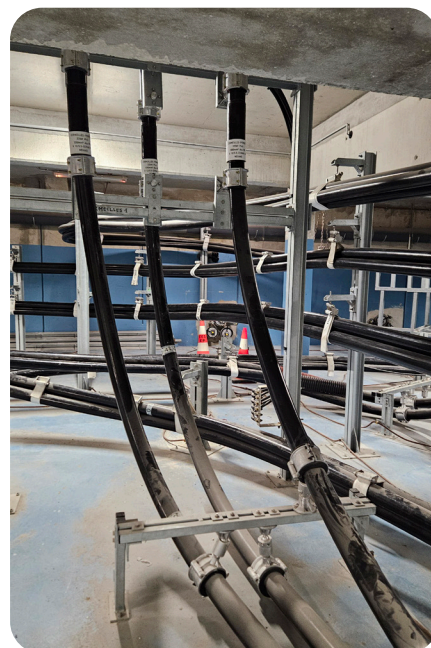



## / OTHER INSTALLATION EXAMPLES



SUPPORT POST + BRACKET AND STRAP CABLE CLEAT



CABLE ROUTING BENEATH TRANSFORMER



SUPPORT POST ASSEMBLY MOUNTED IN PSEM

### Custom support solutions!

A tailor-made solution for your projects

Do you have a specific requirement for routing your cables? Whether for a standard project, a demanding environment or an innovative solution, we design and manufacture structures tailored to your constraints.

Our stainless steel or hot-dip galvanized steel solutions are compatible with our entire range of cable cleats.

Each year, we develop new products to meet our customers' technical requirements.

Why not design the solution perfectly suited to your project together?

For any study request or additional information, we are at your disposal to address your specific needs and provide optimized technical solutions.

Tél. : (+33) 02 43 71 11 80



Your life,  
Our work.



# ACCESSORIES

## / Grounding accessories

50

Brass grounding clamps

Small bracket

Flange for strap cleat on cable conduit

# SCREWING

## / Screwing

51

Castellated nuts

Nuts

Hex screw

Washers



## CABLE CLEATS & ACCESSORIES

### ACCESSORIES

### GROUNDING & FIXING ACCESSORIES

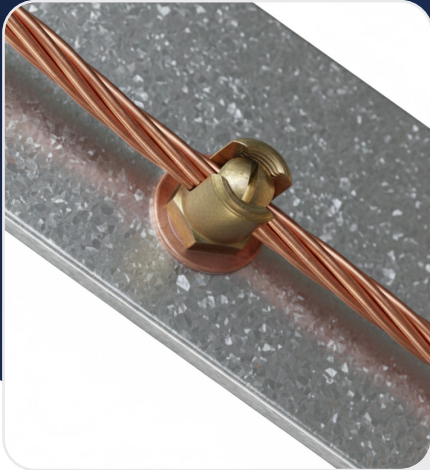

SEF120-7/2RBM

## / BRASS GROUNDING CLAMP

### / DESCRIPTION

- For 120 mm<sup>2</sup> cable
- M7 nut
- Clamping range: 10 - 14 mm

### / MATERIAL

- Washer: bimetal + stud
- Clamp: brass

### Reference

SEF120-7/2RBM

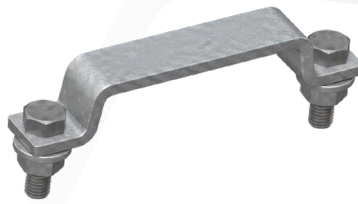
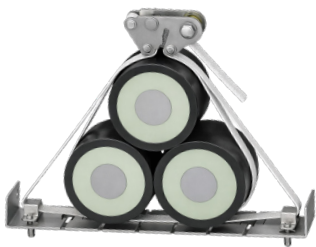

ESB/40

## / FLANGE FOR STRAP CABLE CLEAT ON CABLE TRAY

### / DESCRIPTION

The clamp is used to fix the strap of a cable cleat onto a perforated cable tray. We recommend using two clamps per cable cleat.

### / MATERIAL

AS13 aluminium alloy

### ✓ Supplied with the clamp

- M6 fixing screwing

### + To be ordered separately

- Intermediate strap cable cleat, 40 mm strap width (see page 33)

### Reference

ESB/40



Screw spacing: 80 mm

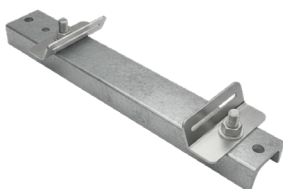

## / STRAP BRACKET



Sold in pairs

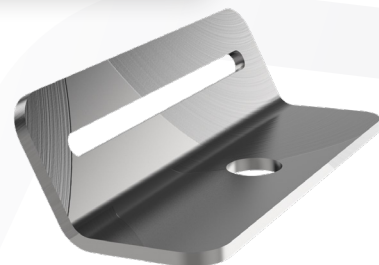

ESR\*\*

### / DESCRIPTION

The small bracket is used to fix intermediate strap cable cleats onto a rail, crossbar, baseplate plate or floor.

### / MATERIAL

Stainless steel

### + To be ordered separately

- Intermediate cable cleat (see page 32)
- M12 screwing (see page 51)

Reference	Associated strap width
ESR40	40 mm
ESR80	80 mm



## / CASTELLATED NUTS



### / DESCRIPTION

Serrated nuts are used as lock nuts when fixing a hinged cable cleat (screw version) or a cable cleat extension onto a baseplate (see page 25).

### / MATERIAL

AU4G aluminium alloy

Reference	Thread
EC16	M16
EC36	M36

## / NUTS



### / MATERIAL

- Stainless steel
- Anti-seize treatment

Reference	Thread
115/E021	M8 (écrou à embases)
115/E032	M10
115/E033	M12
115/E022	M16

## / HEX SCREW



### / MATERIAL

- Stainless steel

Reference	Lenght	Thread
115/V024	M8	35 mm
115/V084		45 mm
115/V025		60 mm
115/V073	M10	30 mm
115/V017		40 mm
115/V090		45 mm
115/V068		70 mm
115/V091		130 mm
115/V097		140 mm
115/V086	M12	150 mm
115/V088		160 mm
115/V028		40 mm
115/V080		45 mm
115/V022		50 mm
115/V092		80 mm
115/V202	M16	140 mm
115/V093		150 mm
115/V089		230 mm
115/V074		20 mm
115/V076		30 mm
115/V082		40 mm
115/V019	M16	50 mm
115/V070		100 mm
115/V087		130 mm
115/V083		140 mm

## / WASHERS

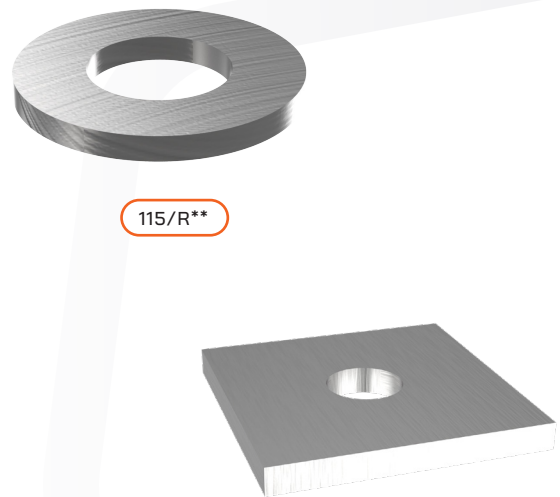

PF-50-50

### / MATERIAL

- Stainless steel

Reference	Dimensions	Associated screw
115/R047	Ø22 mm	M10
115/R050	Ø27 mm	M12
115/R043	Ø32 mm	M16
PF-50-50	Ø50 x 50 mm	M10 / M12



/ IEC 61914 standard table

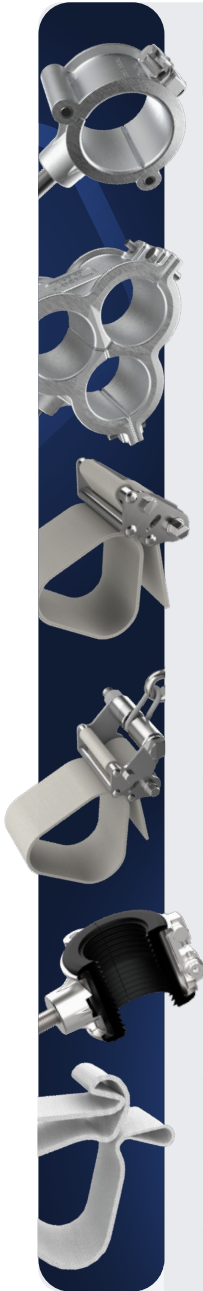

Type	Material	Max. temperature	Min. temperature	Impact resistance	Lateral load	Axial load	UV resistance
CSC**	Metallic	85°C	-25°C	Very heavy	5 000 N	80/140 daN	Compliant
CDC**	Metallic	85°C	-25°C	Very heavy	7 000 N	Not applied	Compliant
CST**	Metallic	85°C	-25°C	Very heavy	2 500 N	Not applied	Compliant
CTSI**	Metallic	85°C	-25°C	Very heavy	Not applied	80/140 daN	Compliant
CSI 20	Composite	85°C	-25°C	Very heavy	6 000 N	Not applied	Compliant
CS2I 20	Composite	85°C	-25°C	Very heavy	Not applied	Not applied	Compliant
CSI40	Composite	85°C	-25°C	Very heavy	10 000 N	Not applied	Compliant
CS2I40	Composite	85°C	-25°C	Very heavy	Not applied	Not applied	Compliant
CSI80	Composite	85°C	-25°C	Very heavy	10 000 N	Not applied	Compliant
CS2I80	Composite	85°C	-25°C	Very heavy	Not applied	Not applied	Compliant
CSI80-QC12	Composite	85°C	-25°C	Very heavy	5 000 N	Not applied	Compliant
Liners	EPDM	85°C	-25°C	Very heavy			Compliant
Strap 20 mm	HR polyester	85°C	-25°C	Very heavy			Compliant
Strap 40 mm	HR polyester	85°C	-25°C	Very heavy			Compliant
Strap 80 mm	HR polyester	85°C	-25°C	Very heavy			Compliant



**IMPORTANT**

Metal cable cleats must be assembled and installed until the covers are fully closed and in full contact. They must be used with liners supplied by PENTA. Composite cable cleats must be tightened at the winding system to a torque of 30 N-m. The M8 locking screw must be tightened once the strap is tensioned.

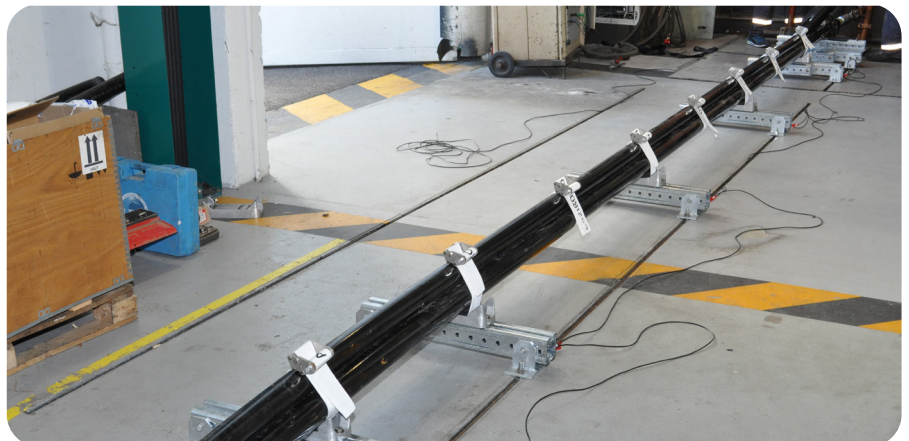



	Fire resistance	Corrosion resistance	Short-circuit current (RMS)	Short-circuit current (peak)	Resistance >1 short-circuit	Cable diameter (ICC test)	Distance S	Distance D	Load per cleat
	Yes	High	29.9 kA	76.1 kA	Yes	51mm	125mm	1m	788 DaN
	Yes	High	29.9 kA	76.1 kA	Yes	51mm	95mm	1m	1036 DaN
	Yes	High	45.3 kA	100 kA	Yes	52mm	66 mm	1m	2576 DaN
	Yes	High	31.9 kA	71.5 kA	Yes	52mm	100mm	1m	869 DaN
	Yes	High	29.4 kA	73.1 kA	Yes	51mm	51mm	0,5m	891 DaN
	Yes	High	29.4 kA	73.1 kA	Yes	51mm	51mm	0,5m	891 DaN
	Yes	High	29.4 kA	73.1 kA	Yes	51mm	51mm	0,5m	891 DaN
	Yes	High	29.4 kA	73.1 kA	Yes	51mm	51mm	0,5m	891 DaN
	Yes	High	31.4 kA	70 kA	Yes	52mm	52mm	1m	1602 DaN
	Yes	High	41.4 kA	100 kA	Yes	51mm	51mm	1m	3333 DaN
	Yes	High	41.4 kA	100 kA	Yes	51mm	51mm	1m	3333 DaN
	Yes	High							
	Yes	High							
	Yes	High							
	Yes	High							

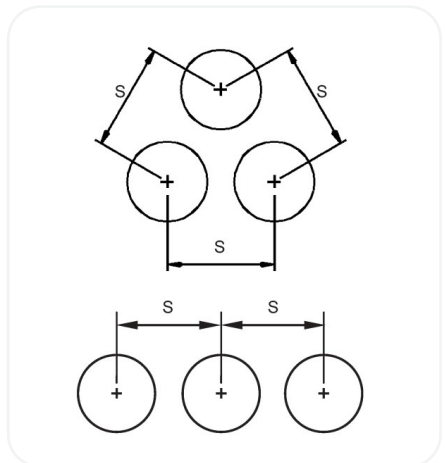
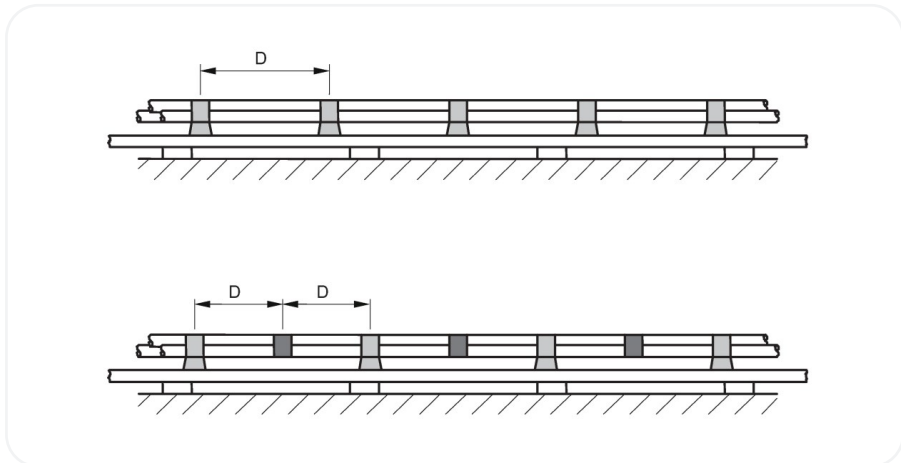

# Notes

A series of horizontal dotted lines for writing notes.

A series of horizontal dotted lines for writing notes.

Tel. (+ 33) 02 43 71 11 80

ALROC SAS

23 rue de la Fonderie

72160 Tuffé Val de la Chéronne France



**PENTA**  
ELECTRICAL SAFETY PRODUCTS

Your life,  
Our work.



[pentaesp.com](http://pentaesp.com)